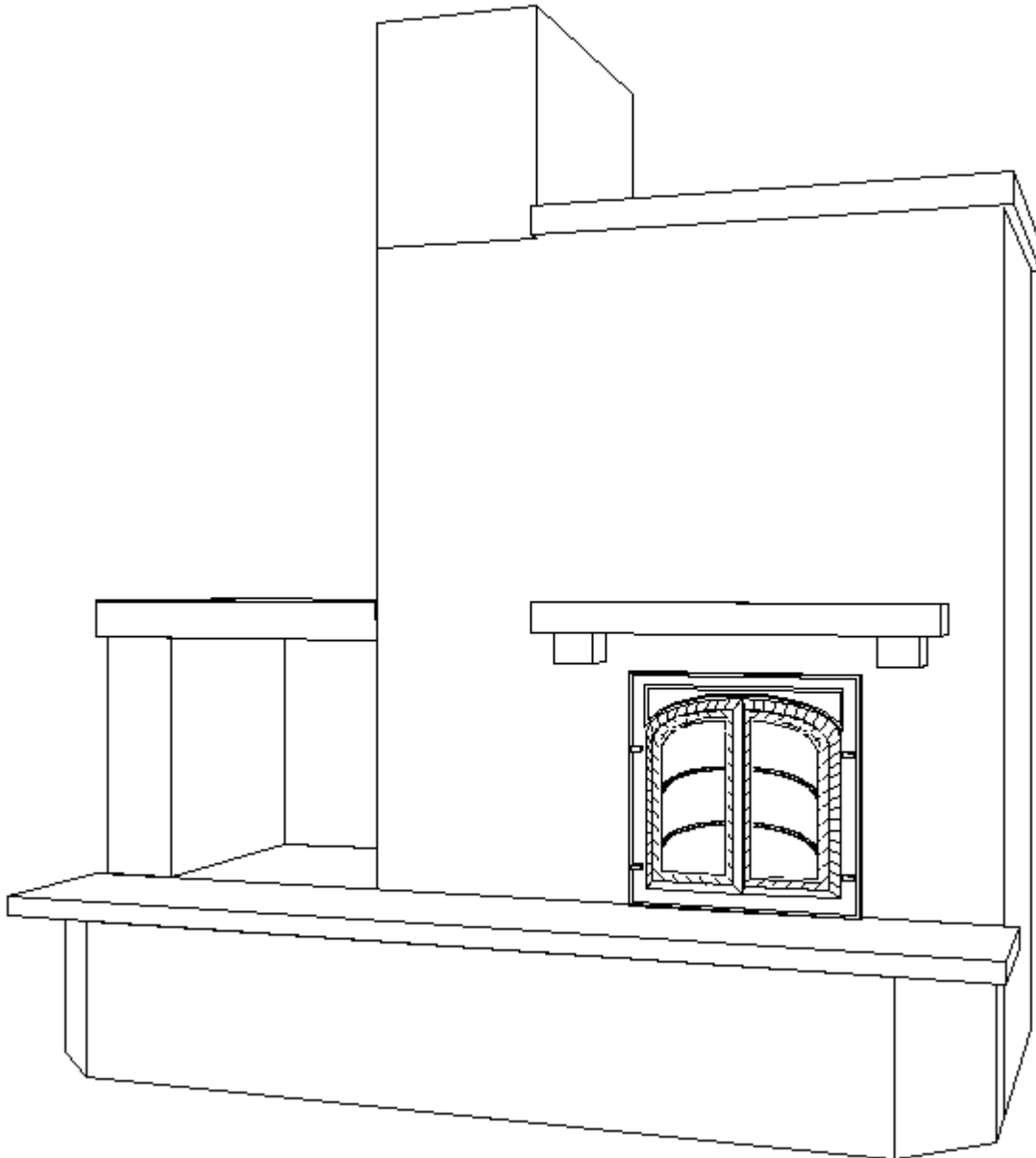


Masonry Stove  
Builders

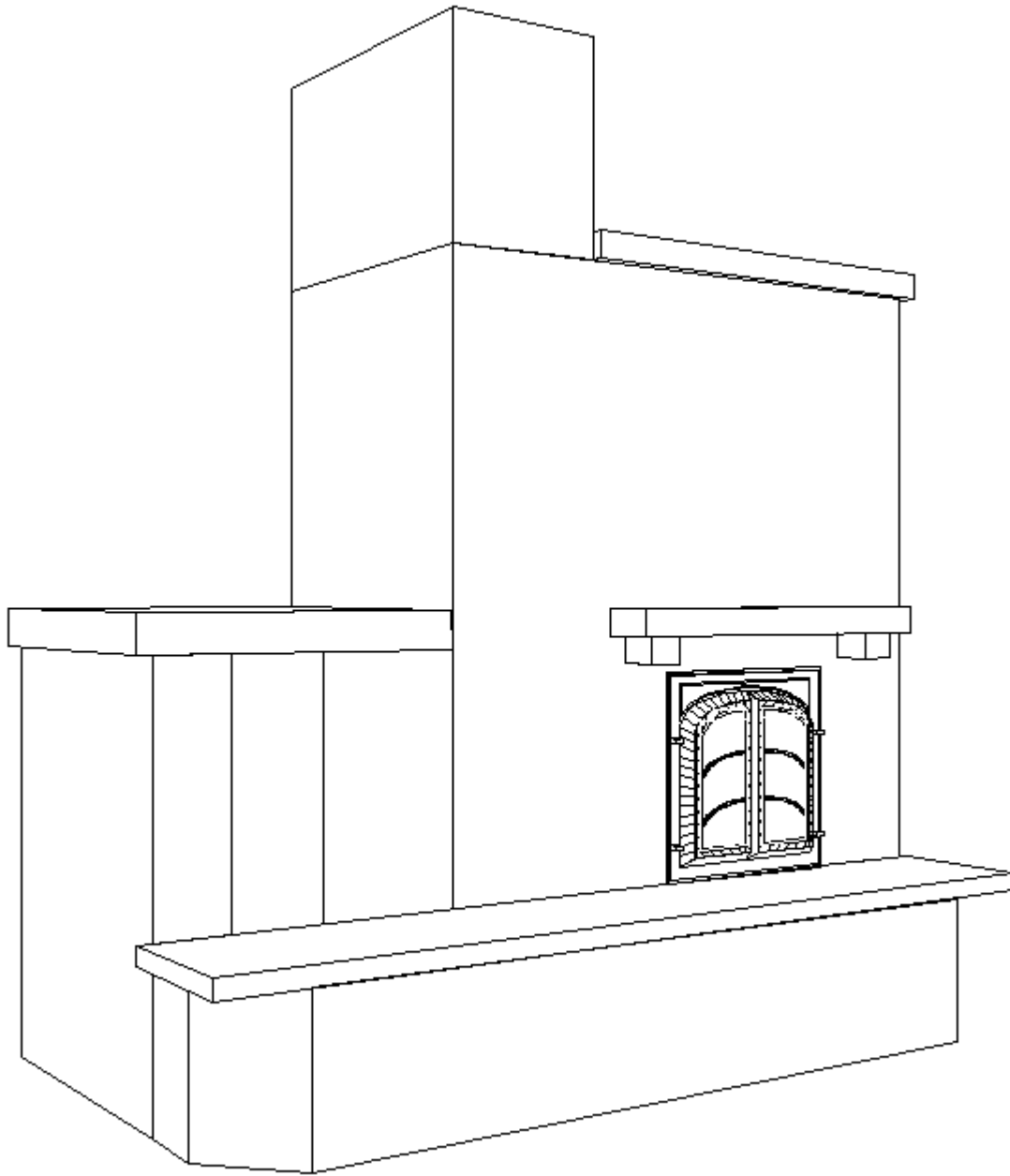
RR 5 Shawville Québec J0X 2Y0

Voice 819.647.5092  
Fax 819.647.6082  
mheat@mha-net.org  
www.heatkit.com

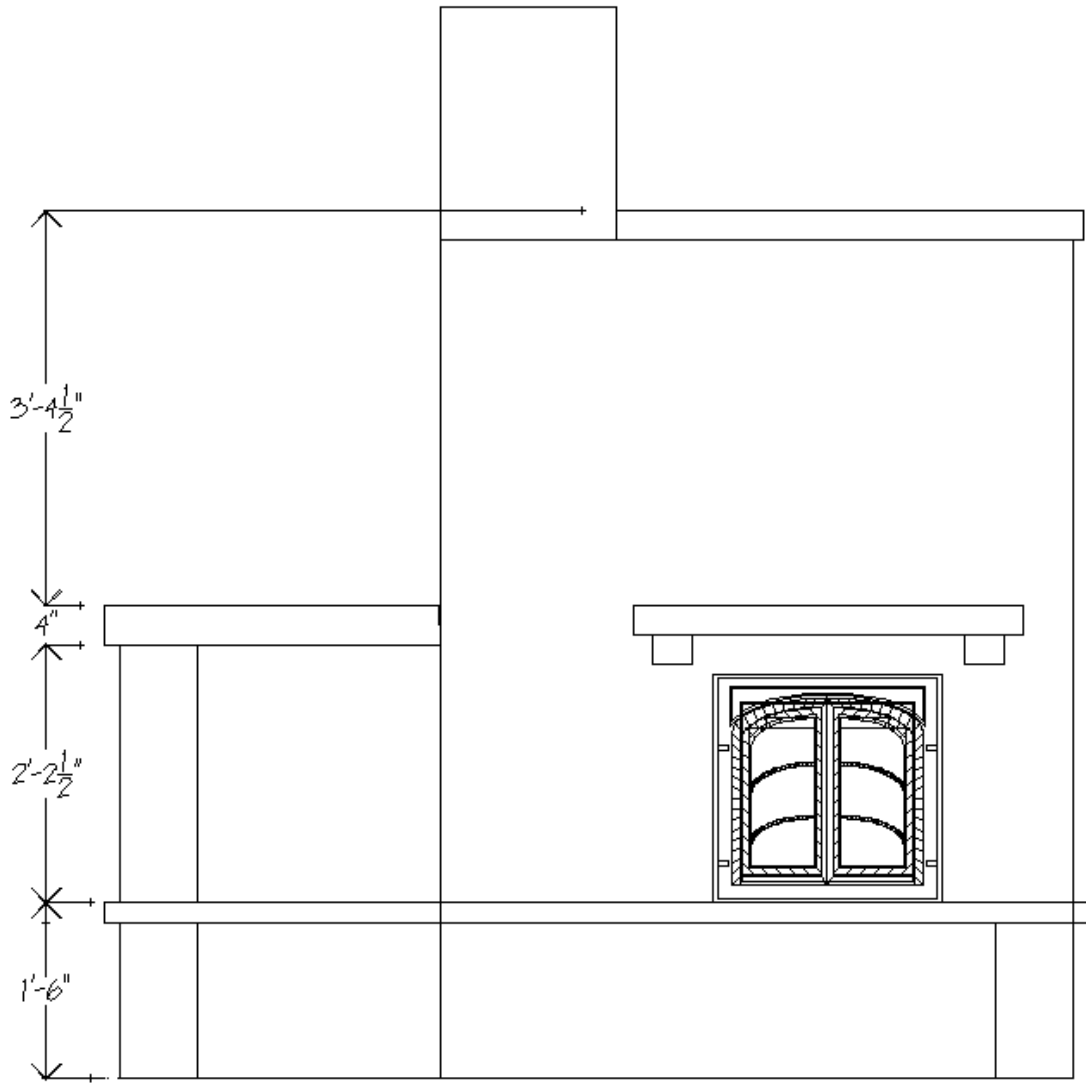
## Drawings for Held Heater



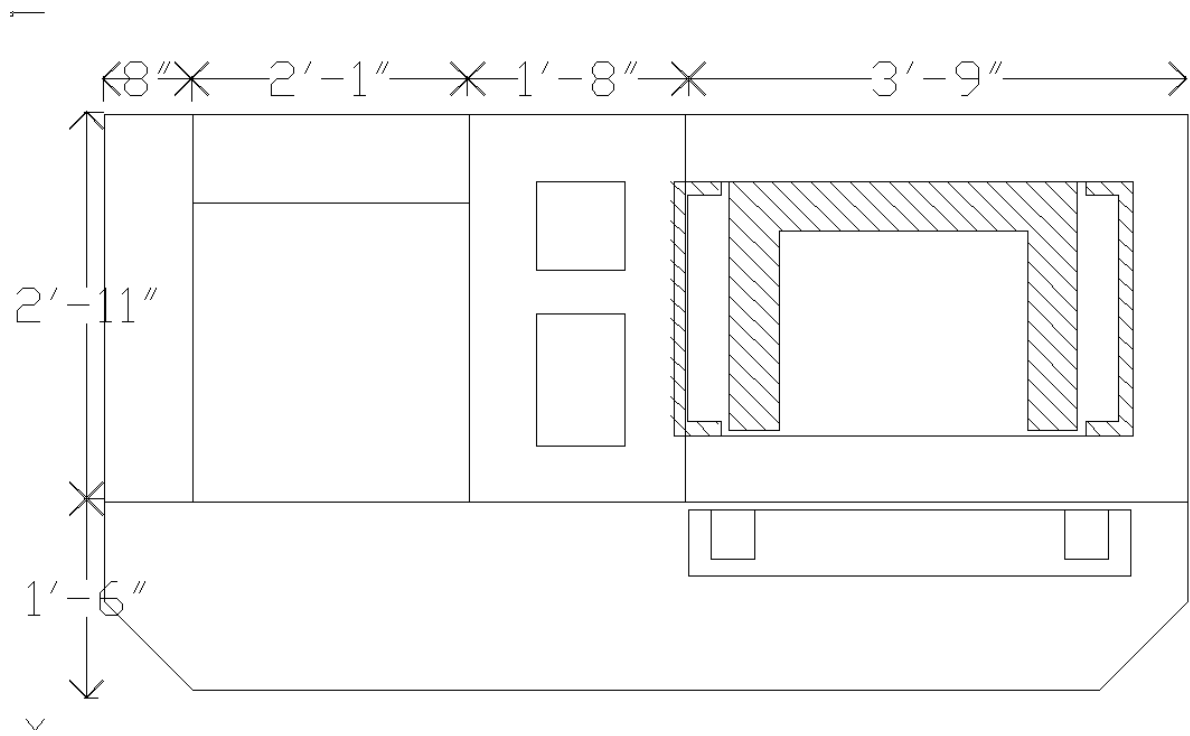
**Figure 1. Perspective (Bench not as built)**



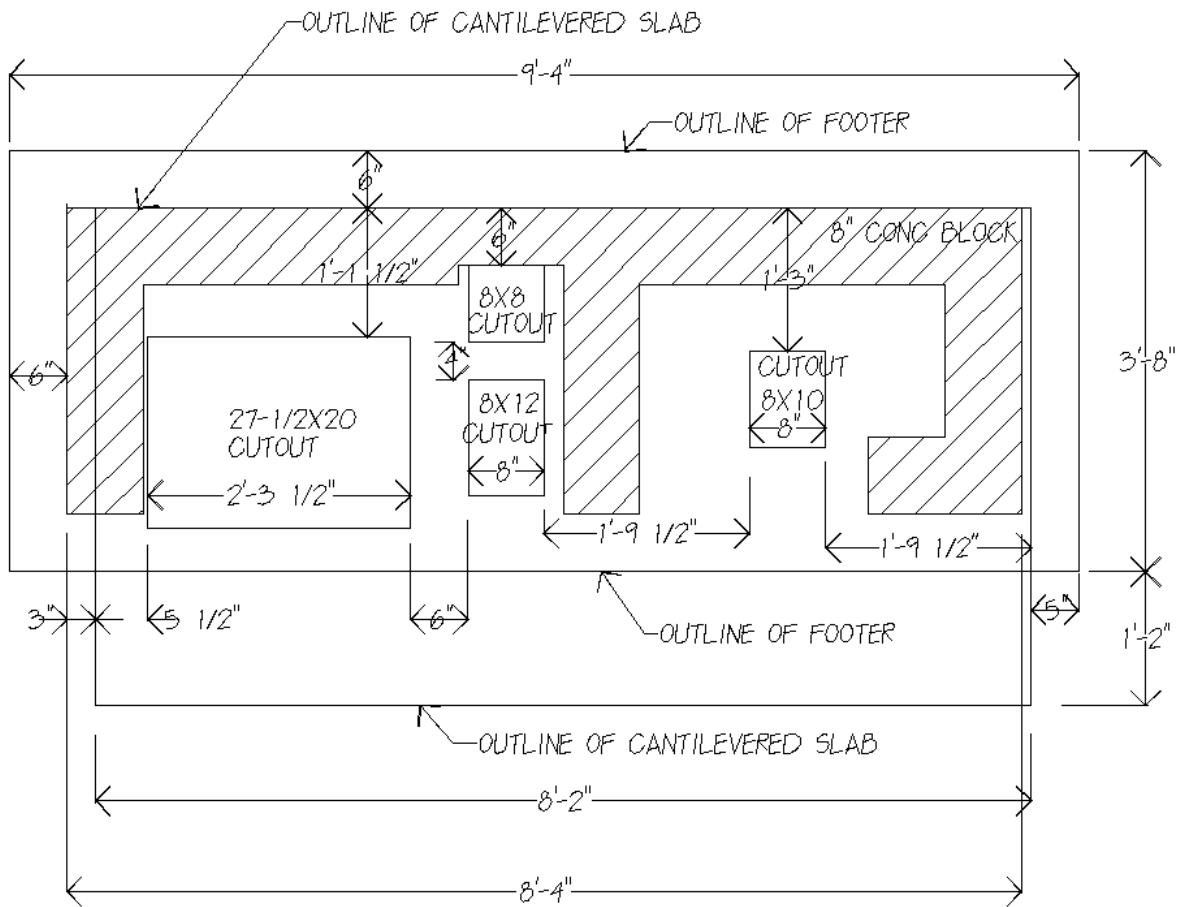
**Figure 2. Perspective (Bench not as built)**



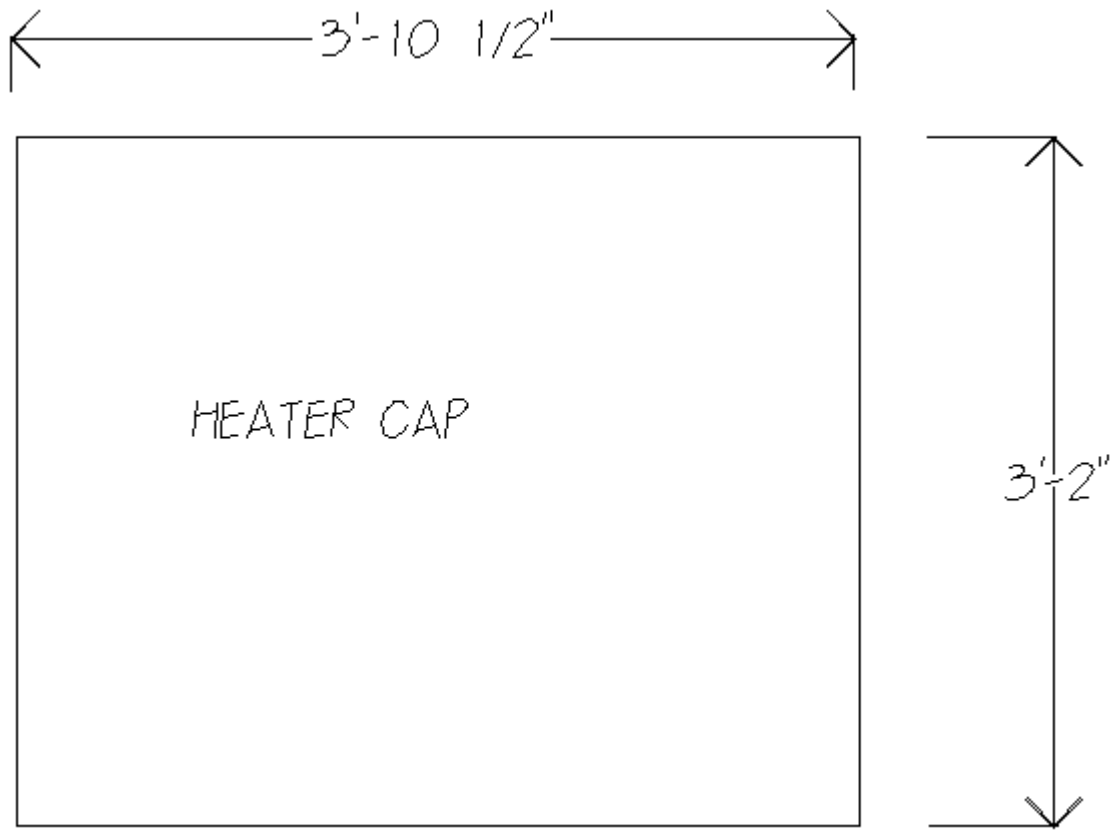
**Figure 3. Front Elevation**



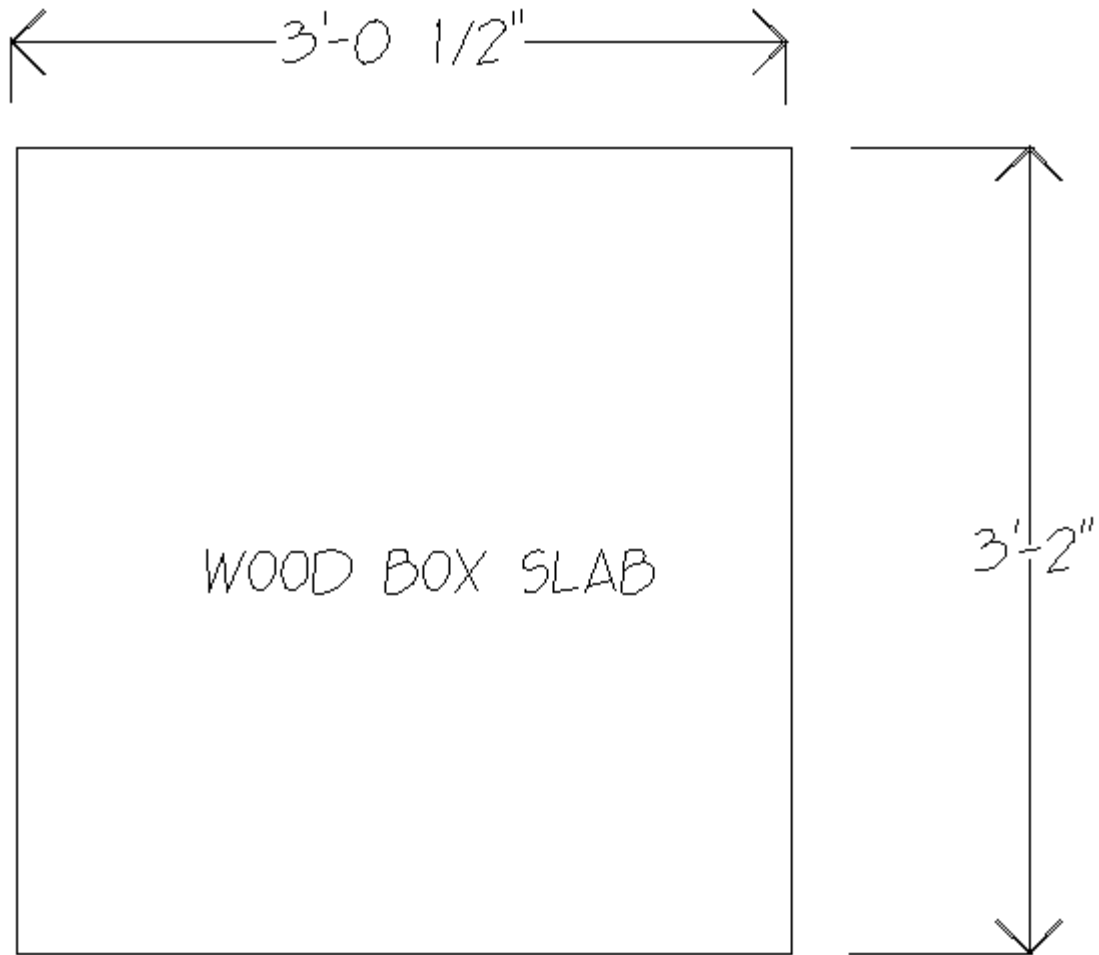
**Figure 4. Plan**



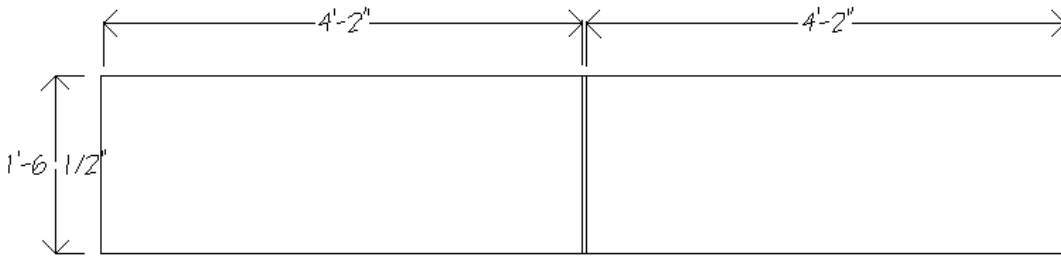
**Figure 5. Foundation**



**Figure 6. 3" Marble Slab to Cap Heater**

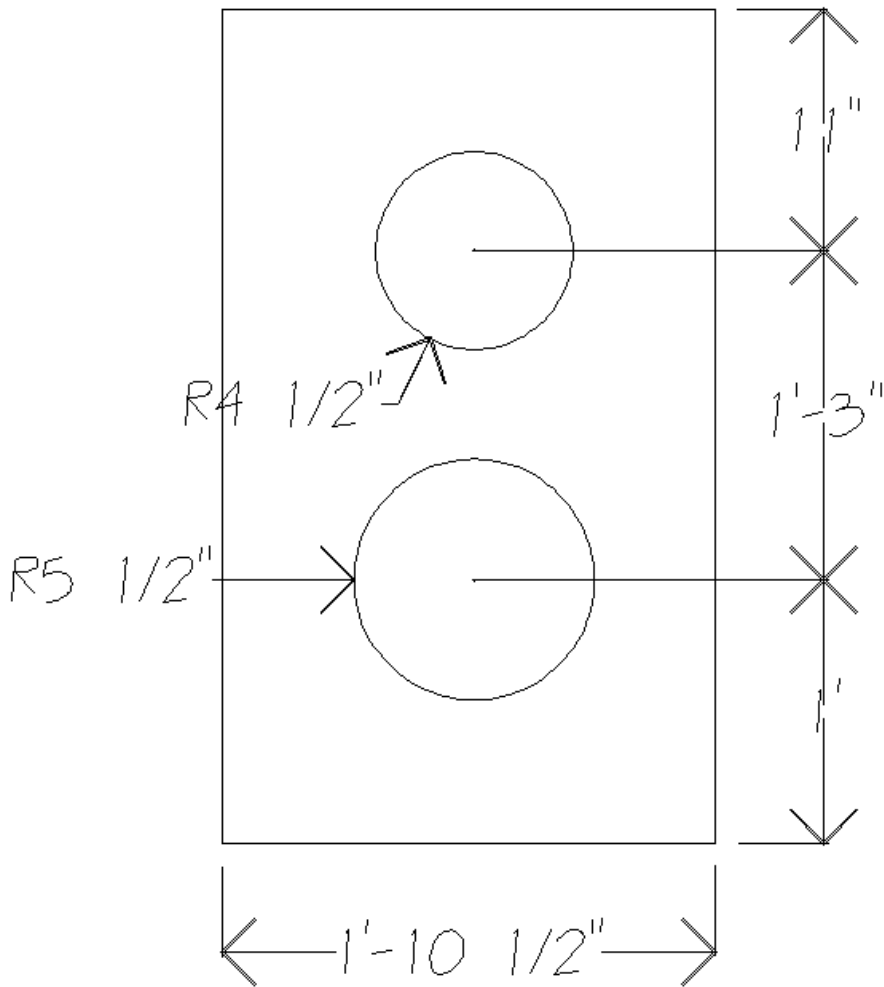


**Figure 7. 3" Marble Slabe to Cap Woodbox**



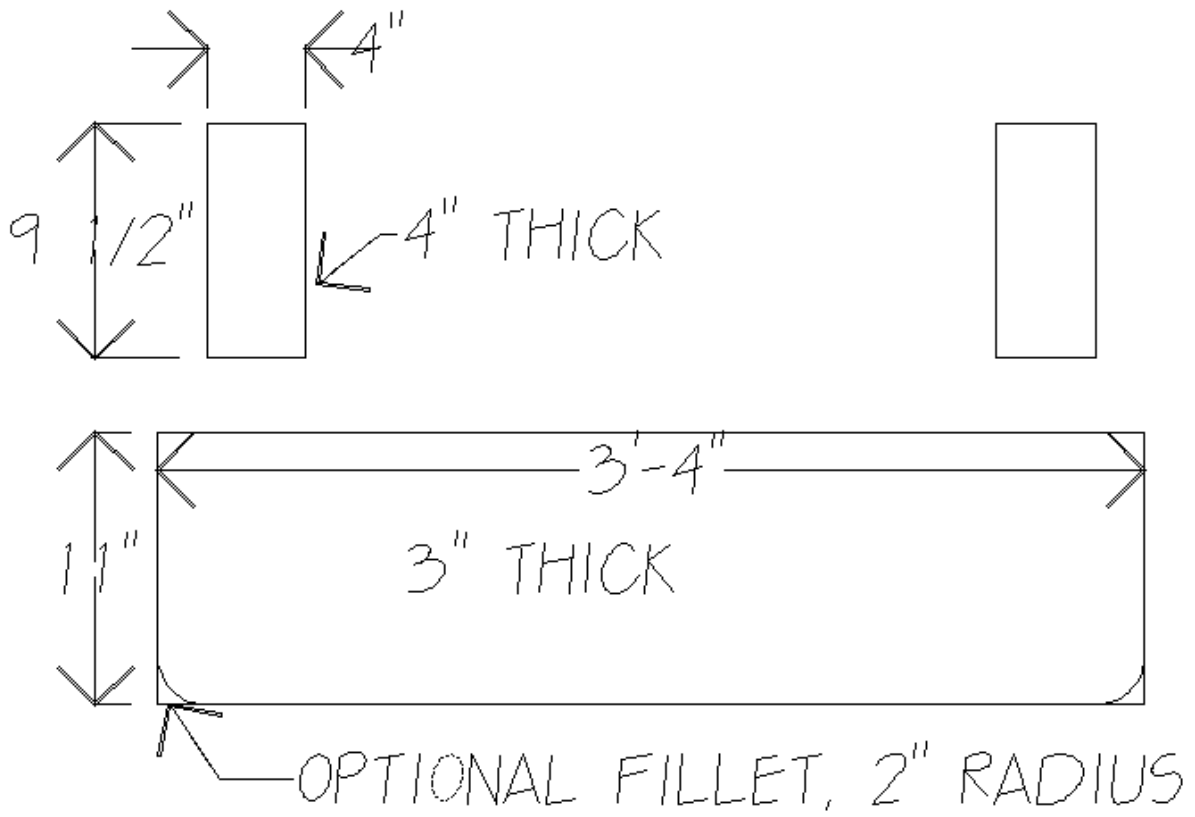
HEATER BENCH SLABS

**Figure 8. 3" Marble Slabs to Cap Heated Bench**

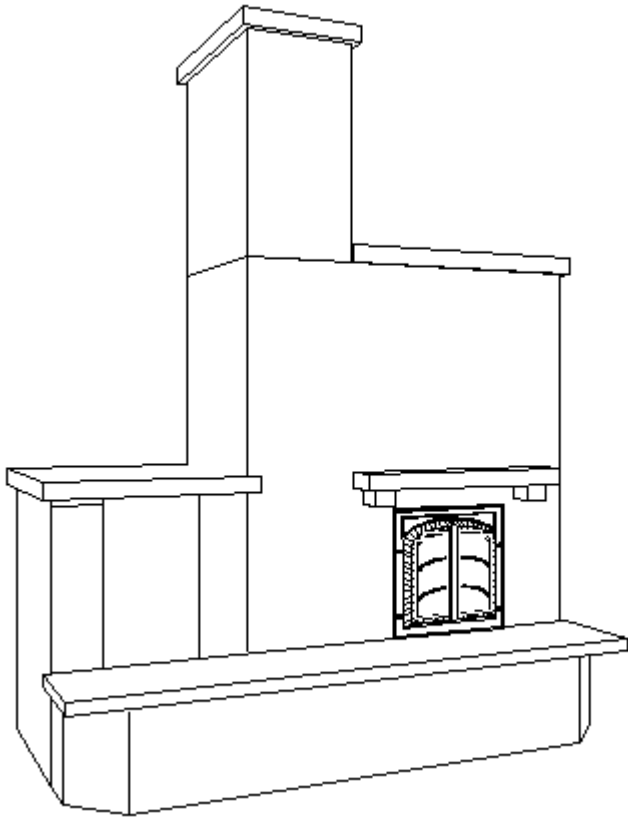


**Figure 9. Marble Slab to Cap Chimney**





**Figure 10. 3" Marble Slabs for Mantle**



**Figure 11 . Perspective Showing Slabs (Heated bench not as built)**