

---

# Heat-Kit System

## Modular Contraflow Masonry Heater Core

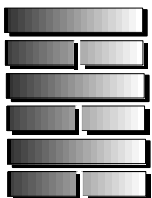
### Assembly Manual

HK-22fo

22" Firebox with Front or Rear Bake Oven

#### Table of Contents:

Material List (in addition to core components) .....	2
Assembling the Bottom End.....	2
Setting Firebricks .....	5
Assembling the Firebox.....	6
Building the Upper Firebox.....	10
Completing The Core .....	22
Fiberglass Slip Joint .....	25



**Masonry Stove  
Builders**

RR 5 Shawville Québec J0X 2Y0  
819 647 5092  
fax 647 6082  
mheat@mha-net.org (Norbert Senf)  
www.heatkit.com

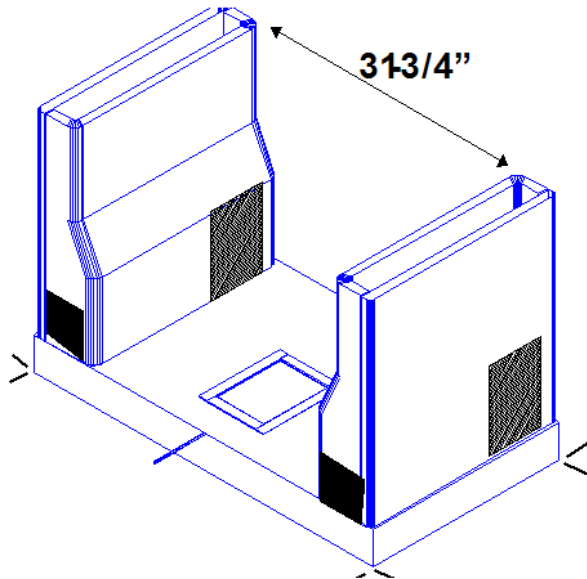
## Material List (in addition to core components)

200	Standard Firebricks 4.5"x9"x2.5" (2.5" dimension may vary. <b>Important:</b> The 4.5" and 9" dimensions are important)
20	Firebrick "Splits" 4.5"x9"x1.25"
30	Common clay bricks (8"x4" nominal). These are used for the fill pieces underneath the firebox floor.
3 bags	"Mortar Mix" (ie., premixed with sand, as opposed to "Masonry Cement", which requires mason's sand)

## Assembling the Bottom End

The bottom end of a contraflow heater is the most complicated part of the whole job. The two downdraft channels connect here, underneath the firebox. As well, the chimney connection and the cleanout openings for the particular installation need to be determined and located here.

We've removed as much of this complication as possible with the Heat-Kit system. The insulated base slab allows you to do a dry layout first and make sure that everything is located properly in relation to the chimney and the slab. As well, our thinwall refractory castings simplify the job of making the necessary cutouts with a portable masonry saw or a skilsaw. If you take a little extra time at this stage, particularly with the layout, you'll avoid problems later on.



**Figure 1.**  
**2 Base channels sit dry on insulating base**

Position insulating base slab dry to determine layout for heater and chimney.

Mark final position at corners with a pencil.

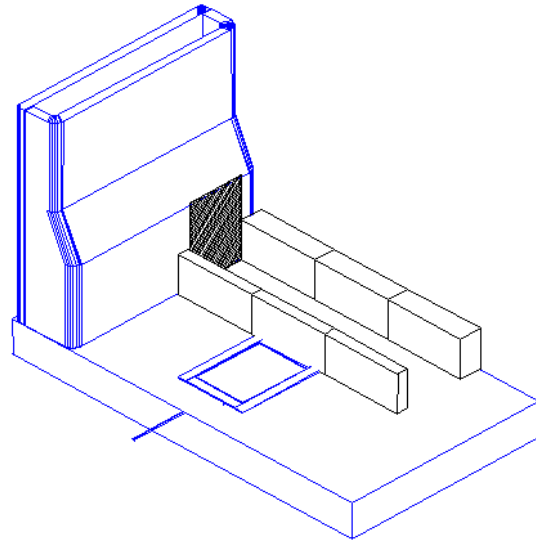
Install insulating base slab level onto a mortar bed.

Before setting base channels, determine the best place in your layout to locate the cleanouts. One is needed for each base channel.

Mark clean out cuts on the base channels. Mark chimney connection on base channel.

Cut appropriate holes for chimney connection and for clean outs. In this example, a right side chimney and front channel cleanouts are shown.

Set base channels dry as shown. Bottom seam will be sealed later by mortar slush between channels and facing.



**Figure 2.**  
**Connecting channel is started**  
**Right base channel not shown (for clarity)**

Build connecting channel, using refractory mortar.

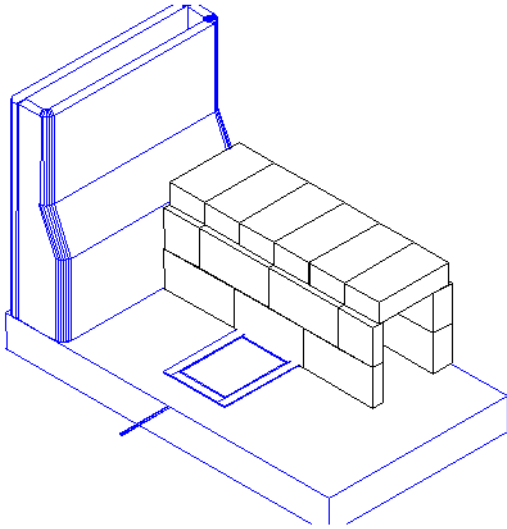
(If there is a rear chimney, leave opening and span with flat bar supplied (notch bricks to accept flat bars, thus allowing you to maintain thin joints)).

Firebrick shiner is flush with outside of slab. Firebrick split shiner is set to form a 6-1/2" channel.

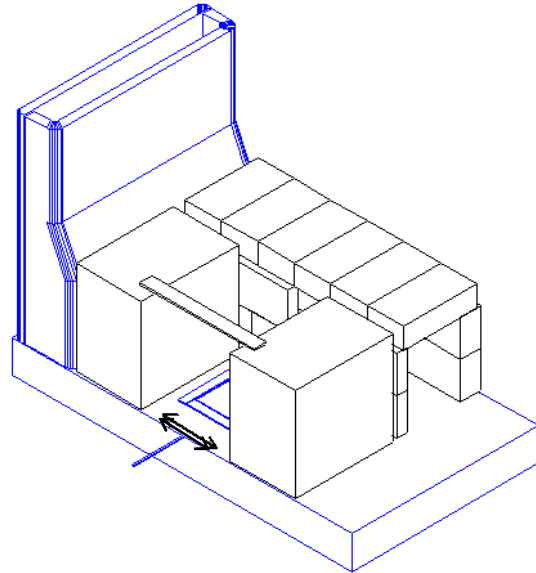
(Note: "shiner" = brick set on edge)



**Figure 3**

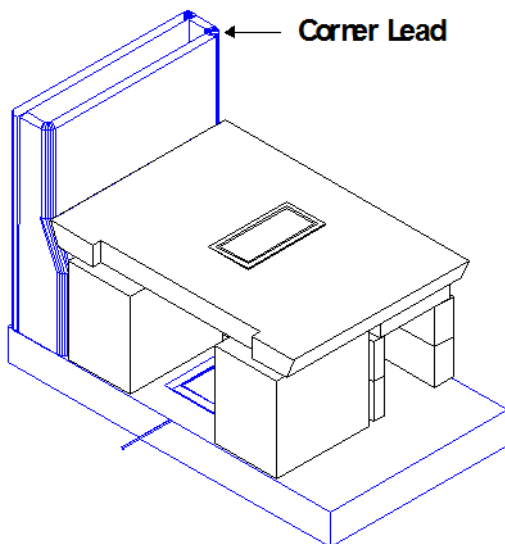
**Figure 4**

Form connecting channel ceiling as shown.  
Sponge inside of channel to remove hanging drips.  
Fill any large gaps between bricks and lower channel with regular mortar.

**Figure 5**

To form support for firebox floor, build up fill as shown to same height as firebrick. Use the 30 common bricks (see materials list) for the fill pieces. Arrow indicates approx. 8" channel for ashes.

Install 14" flatbar as shown to provide extra support for firebox floor. Use mortar joint to gain height.

**Figure 6**

Install firebox floor onto generous mortar bed and level accurately.

Back corners of floor line up with leads that are precast into lower channels.

Ensure full mortar bed between flat bar and floor.

You are now ready to build the firebox.

**Note:** the floor shows a cast iron pivoting ash dump, which has been replaced by a rear grate (see Figure 8)



**Figure 7**

View of assembly up to firebox floor level.  
Note that the fill bricks underneath the floor have been dry stacked in order to come out to the right height. Mortar is used to seal the head joints and the spaces between the bricks and the rear and side channels.

The 2 steel flat bars are mortared, and there is a full mortar bed between the flat bars and the firebox floor.

The two lower channel cutouts in this installation are connections for a heated bench.



**Figure 8**

(Dec /08) Updated view of firebox floor, with hole for rear grate. Note that it overhangs the firebrick connecting tunnel, and the back of the hole is filled with mortar and angled to form a chute for the ashes.

## Setting Firebricks

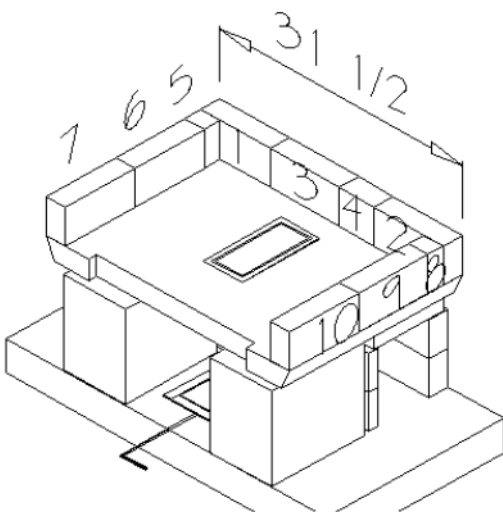
Firebricks are laid up with clay air setting refractory mortar (“Sairset”, or fire cement) with thin joints. Only enough clay needs to be used to completely fill the joint. No joint thickness needs to be built up - you are only filling in gaps and irregularities between the bricks. Although masons are used to trowelling firebricks, the best joints are obtained by dipping the bricks into mortar that has been thinned to the right consistency. It looks messy, but the cleanup is easy later with a sponge.

The Sairset that comes with the heater core kit is at trowelling consistency. For dipping, you will need to thin it with water. A drill powered drywall mud mixer works well for this. You can tell if the Sairset has the right consistency by floating a firebrick in it. It will sink about half way. We like to dip the bricks and also keep a margin trowel (small rectangular trowel) handy for the odd bit of trowelling.

## Assembling the Firebox

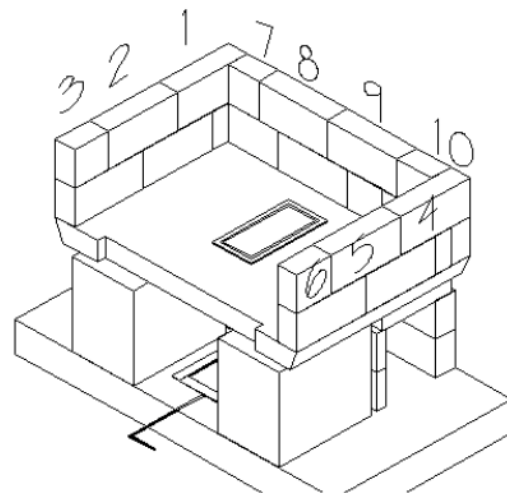
The firebox is laid up from standard firebricks. Standard firebricks are 4 ½” wide by 9” long by 2 ¼” thick. The thickness will vary between 2 ¼” and 2 ½” depending on the supplier. Since the Heat-Kit is designed around the standard firebrick module, it is important to check the width and length of your bricks beforehand, to avoid having to make modifications to the assembly procedure.

The firebox consists of two shells of firebricks set on edge. This allows the inner shell to be a field replaceable firebox liner. The firebrick installation sequence has been numbered. By following this order, you maximize the ability to “bury” odd lengths where they don’t show and reduce the amount of precise cutting that you have to do. Note that full contact between inner and outer shell is not required at the inside corners. Where convenient, a little play right at the corner provides some expansion room for the liner.



**Figure 9**

Lay out the firebox as indicated, using air setting refractory mortar. Line up back corners with the leads that are precast into the lower



**Figure 10**

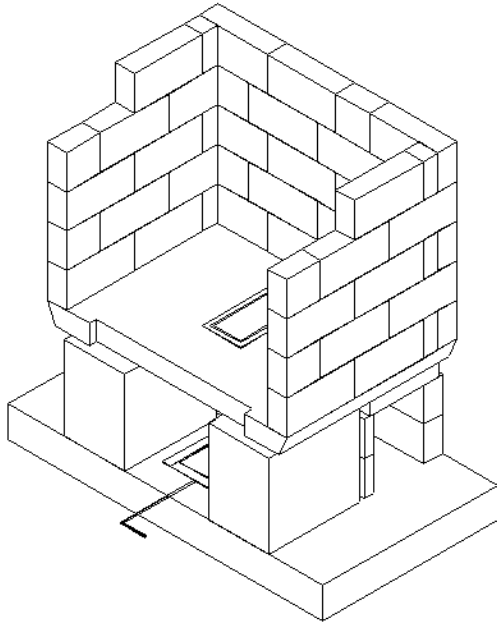
Exact bond is dependent on firebrick thickness, generally between 2-1/4” and 2-1/2”.

Heat-Kit 22fo Assembly Manual  
channels (bottom channels deleted from  
drawings for clarity).

Printed on 1/11/2011

Outer width of firebox is 31 1/2". Firebricks sit  
dry against base channels.

Figure 9 shows the firebricks numbered in the  
order in which they are installed.

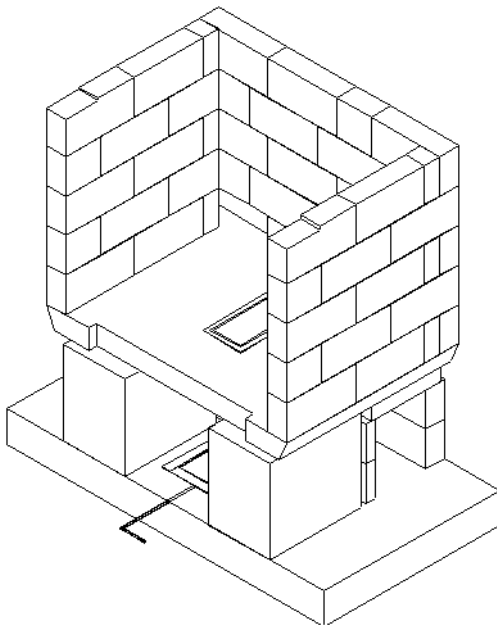


**Figure 11**

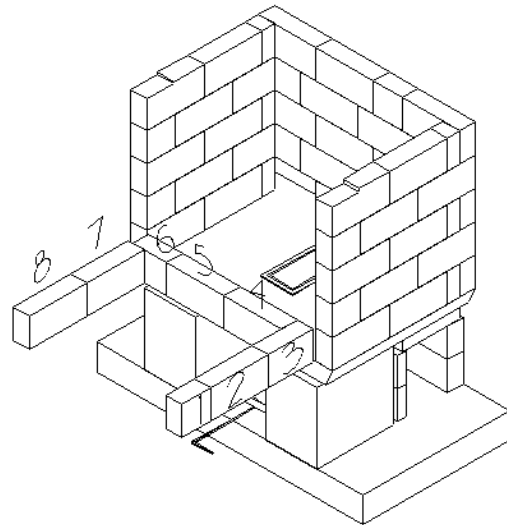


**Figure 12**

Completed outer shell. Note that hole in floor  
is not as shown in this photo.



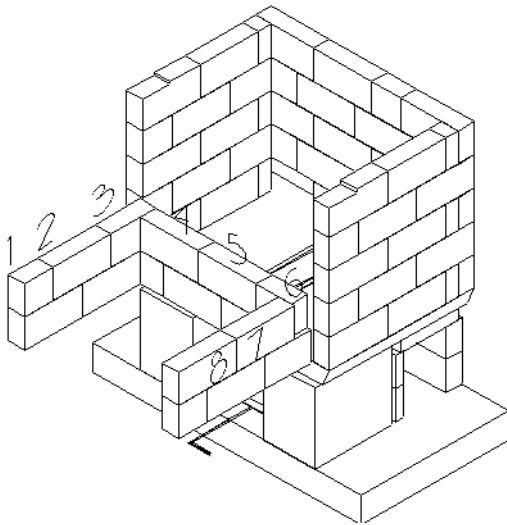
**Figure 13**



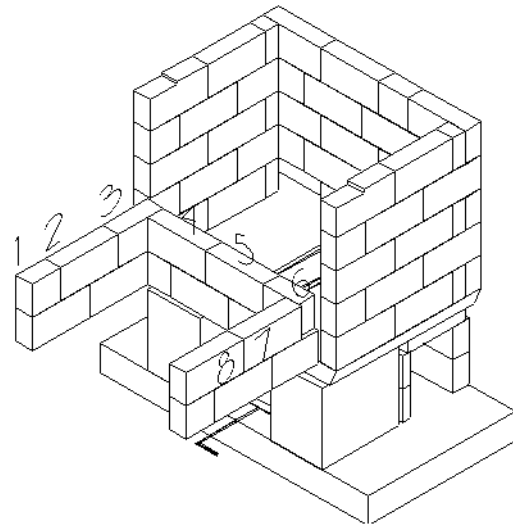
**Figure 14**

Top front firebricks are notched 1/4" x 4" for firebox lintel.

Begin inner firebox. Note that the bricks are left about 1/4" short at the blind inside corners. The cut edges on these bricks are hidden.

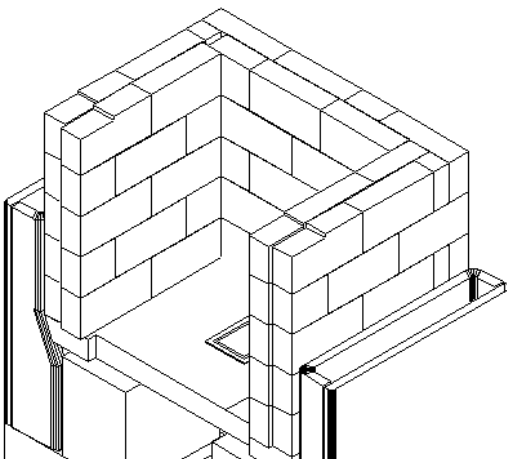


**Figure 15**



**Figure 16**

The inner firebox is set dry against the outer firebox. There is no mortar joint between the two fireboxes.



**Figure 17**

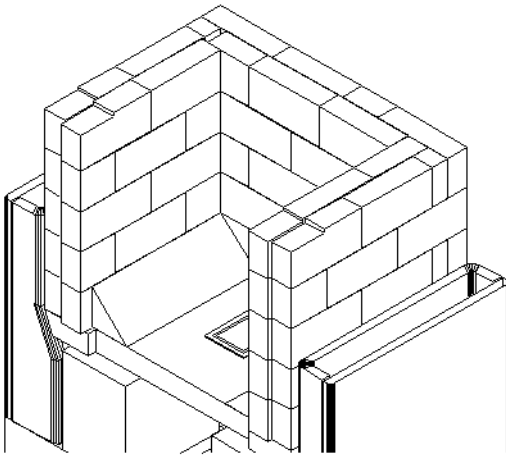
Notch top course of liner as shown. Notches are 1/4" x 4"



**Figure 18**

Immediately wash down the firebox with a sponge and a liberal amount of water. Rinse with clean water. If this is done right away, it is easy to get a clean looking firebox.





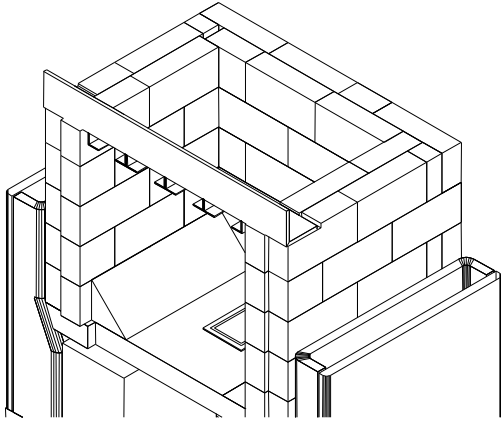
Firebrick floor slopes are glued in place with Sairset - this can be done later.

Continue at Figure 20

**Figure 19**

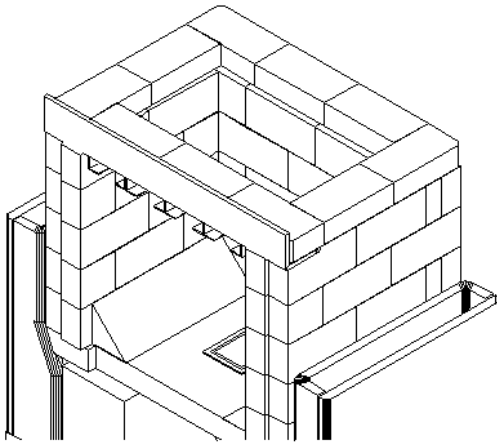
## Building the Upper Firebox

***Rear Bake Oven:*** The drawings below show a front bake oven. For a rear bake oven, reverse the plan at this point. In other words, flip the remaining layout by 180 degrees.



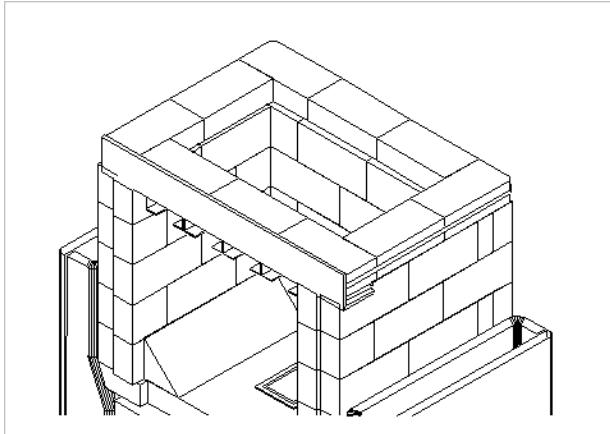
**Figure 20**

Install firebox lintel. Brackets on lintel are for heat shields (firebrick splits, installed later, see Figure 59).



**Figure 21**

Lay up next course as shown. Use a dry joint with lintel.

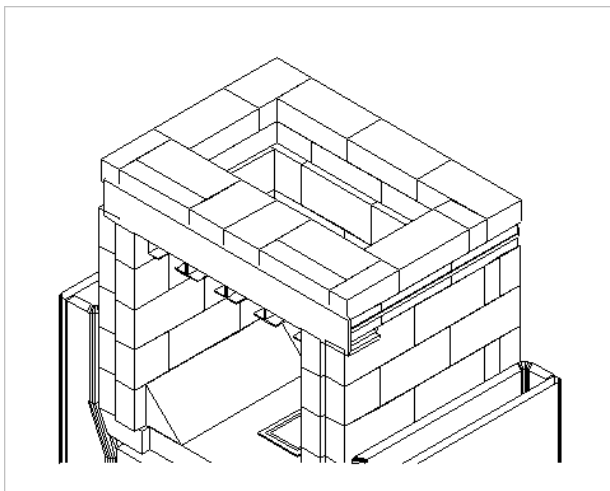


**Figure 22**

If you have access to strapping tools, this course can be strapped as shown. This is optional. If a strap is used, then round outside corners of bricks slightly.

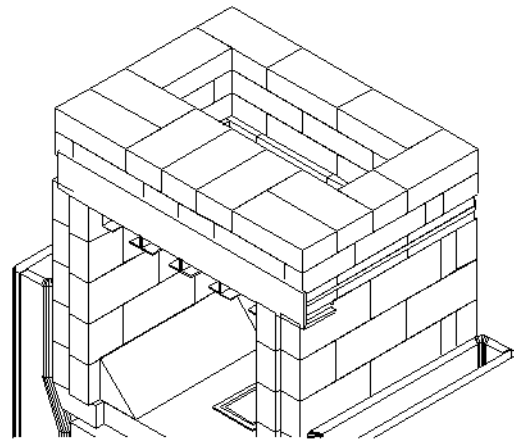
The purpose of the strap is to transfer weight onto the outer firebox.

This allows the complete inner firebox to be removed, if necessary, rather than in sections.



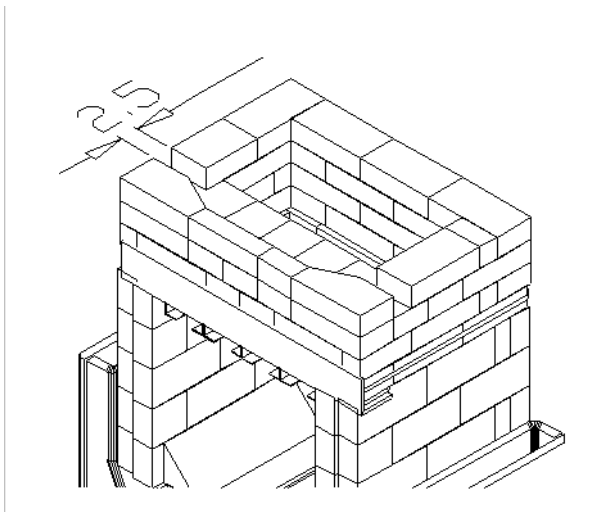
**Figure 23**

A total of 10 soaps (5 bricks ripped lengthwise) is used. All bricks are either full length (9"), 3/4 length (6 3/4") or half length (4 1/2")



**Figure 24**

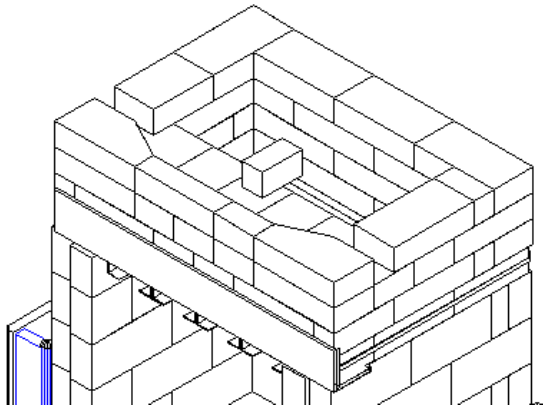
Next course.



**Figure 25**

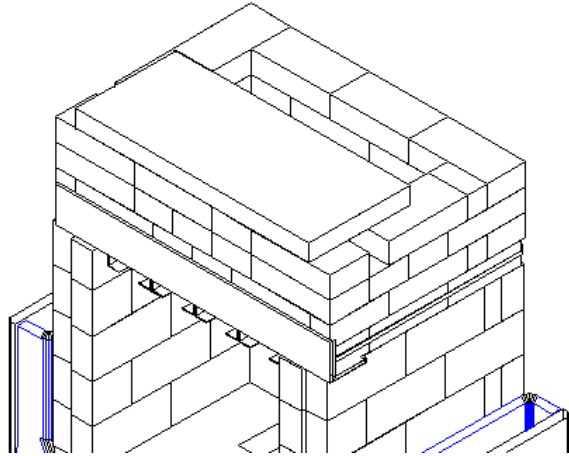
Check bricks for level before starting this course to see if there are high or low spots. When setting this course, carefully level the section where the oven will sit.

Cut front corner bricks as shown. Leave oven floor heat bypass gaps as shown. Standard gap is 2 ½ inches.



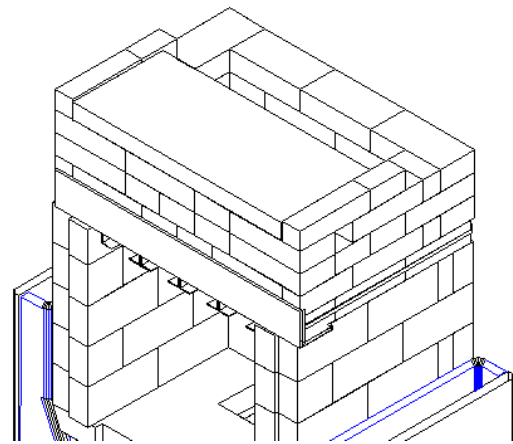
**Figure 26**

Install small floor support piece as shown.



**Figure 27**

Install oven floor as shown. Set floor into Sairset. Use a generous bed, to give you a bit of extra leeway so that you can level it carefully.



**Figure 28**

Install soaps as shown and level.



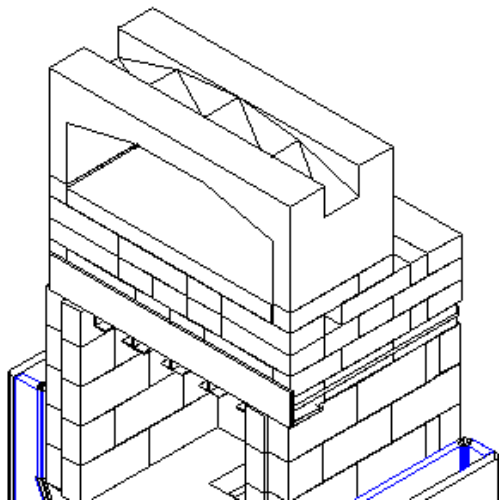
Note generous mortar along bottom edge, to provide a gas seal. Top edge is left open, and will be sealed with a rope gasket.

**Figure 29**



**Figure 30**

Oven will sit on these bricks.  
Make sure they are level.



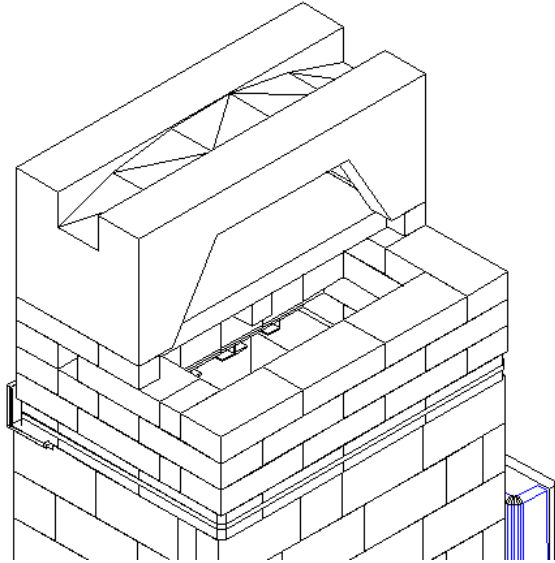
**Figure 31**

Apply Sairset to the soaps that will be under oven sidewalls. Make sure that you have adequate foot scaffold, and install large oven casting as shown.

Use a helper, being sure to set oven straight down. Oven is heavy. Plan your moves, and don't twist while you lift. A third person sticking his fists in the centre, to take off some weight, makes the job a lot easier.

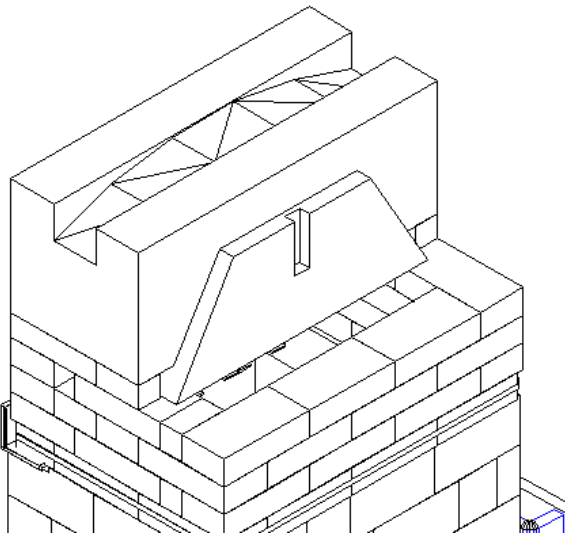
The oven and floor are flush with the outside of the core.

Note: ignore the extra lines on the drawing of the oven itself. These are an artifact of the CAD drawing system.



**Figure 32**

View from rear.



**Figure 33**

Install oven back.

Slide forward until it contacts back oven floor.

Back of oven floor should be tucked into the recess in the oven back piece.

Go to front and check gap between top of insert piece and oven.

Gap should be as narrow as possible.

If necessary, shim up oven back with cut-up brick ties to ensure snug gasket space at top (when viewed from the front)



**Figure 34**

View from front with oven back installed.

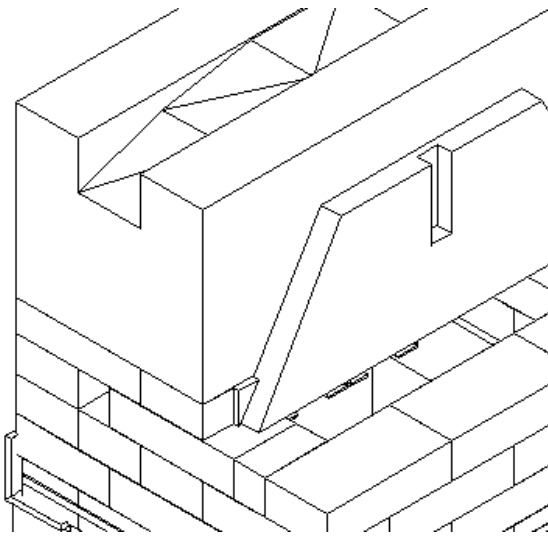
Note tight gap at top.

Look along the bottom of the oven back, and note the gap to the bake oven floor, which will receive a fiberglass rope gasket.

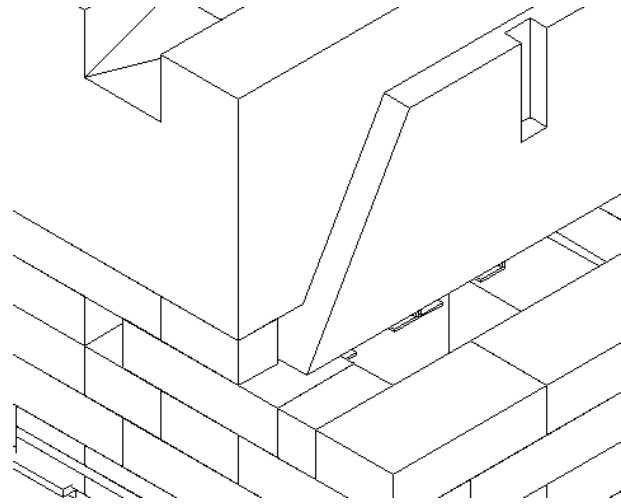


**Figure 35**

View from the back



**Figure 37**



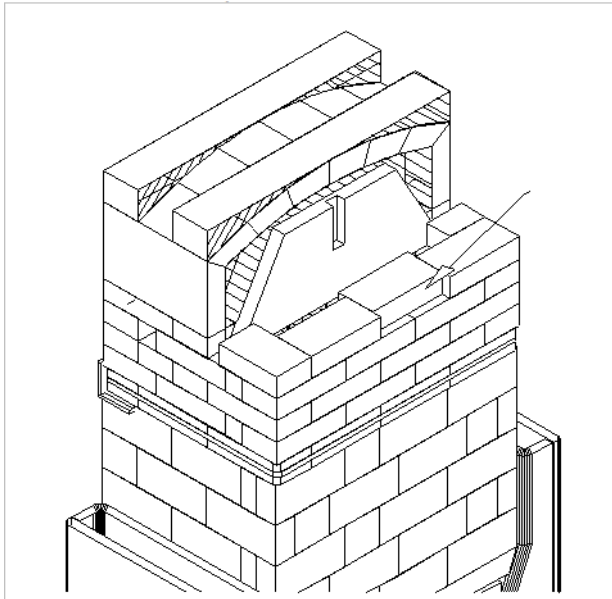
**Figure 36**

Closeup of rear corner of oven.

Install small wedge cuts (supplied) where shown. Mortar them in with Sairset.

Push wedge in until it contacts rear of floor.

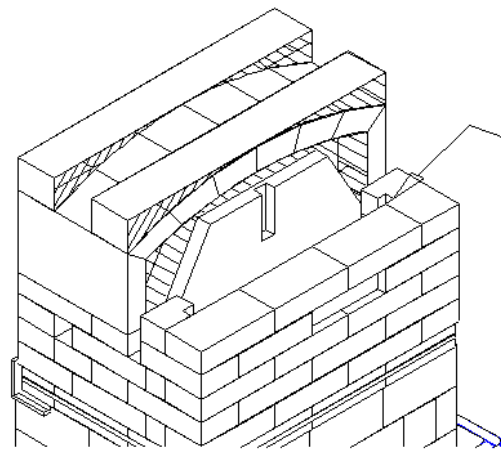
From the front of the oven, scrape out excess Sairset from the corner recess.



**Figure 38**

Project back brick 3/4" as shown to form ledge for millboard.

The recess formed by the setback brick can be filled later with ordinary mortar to maintain a smooth surface on the outside of the core.



**Figure 39**

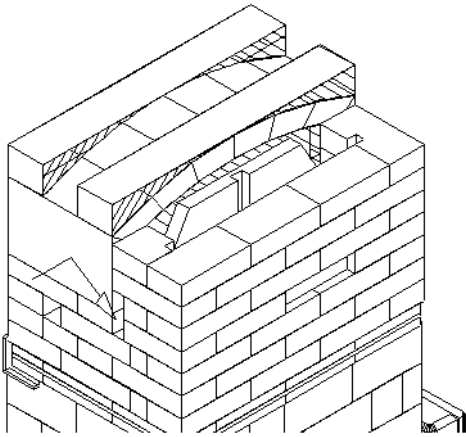
Form notches as shown for 1 inch millboard. Make notches slightly over 1 inch to allow for irregularities when sliding in millboard. The easiest way to cut these notches is to make 2 or 3 saw kerfs and pop the piece out with brick hammer.

There are 5 courses of notches.

Note that first two courses of notched bricks are shorter, to clear oven back insert.

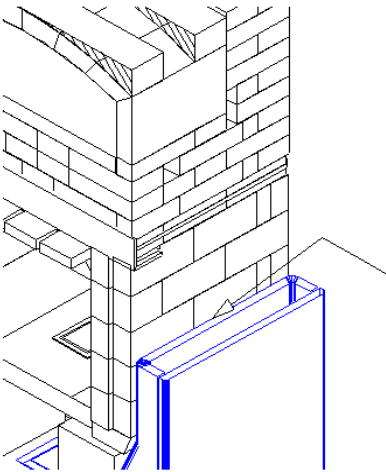


**Figure 40**



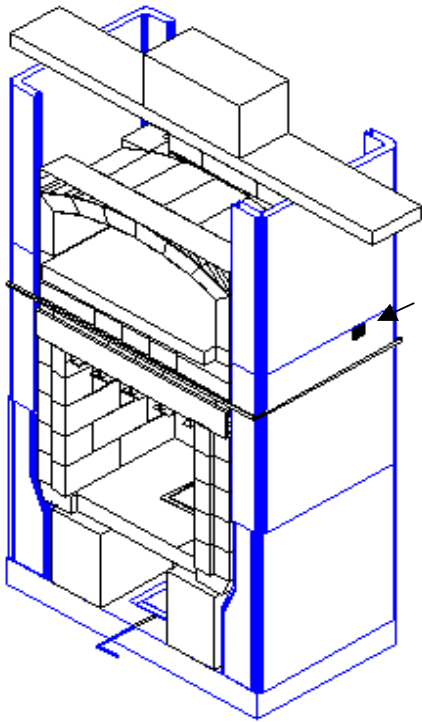
Continue as shown

**Figure 41**



Seal horizontal gap between lower channels  
and heater with a bead of silicone

**Figure 42**

**Figure 43**

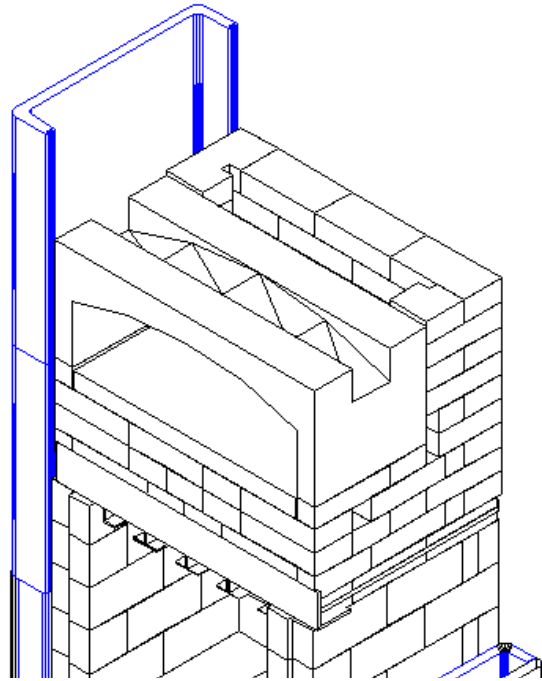
For easier heater startup during difficult conditions (cold heater, warm outside temperatures) we highly recommend installing a gas slot. This consists of a 2" X 2" direct connect. In the above example, the arrow shows the location for a right side chimney towards the back of the heater. Cut a notch in the channel at the appropriate location. Later, when facing the heater, create the direct connect to the flue liner by using firebricks or firebrick splits (see Figure 45).

Install middle channels onto a bed of Sairset.

Strap middle channels or use tie wire. When strapping, compress expansion joint gaskets no more than 50%.

Clean off joints from inside. Make sure there is no mortar bridging at the expansion joints from inside.

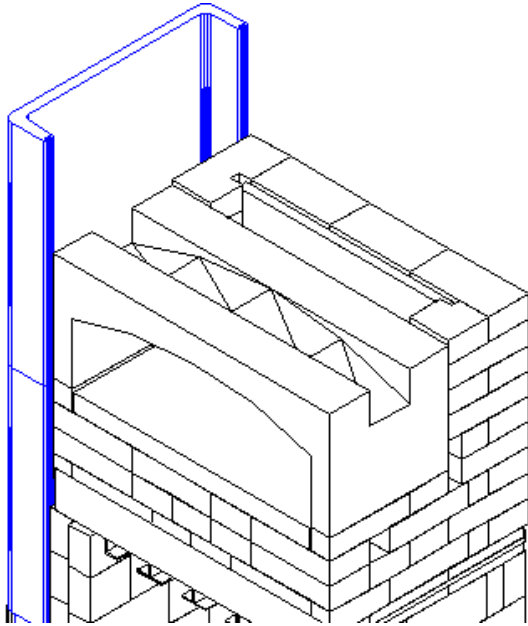
Install top channels and brace temporarily as shown.

**Figure 44**

Right channels not shown for clarity.

**Figure 45**

Gas slot detail



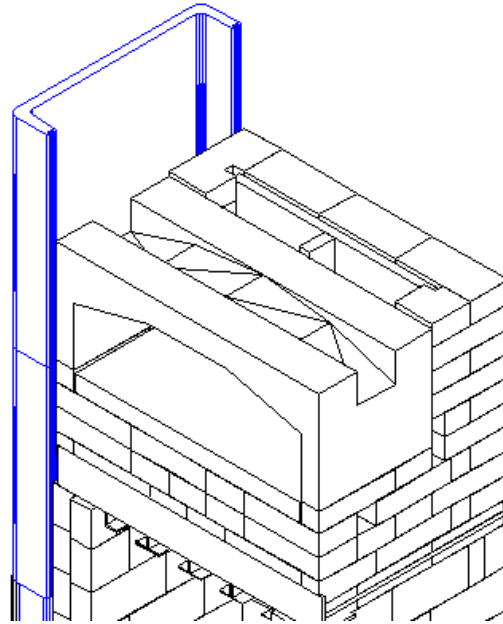
**Figure 46**

Slide in 24 1/2" x 12" millboard. Handle millboard carefully.

The purpose of the millboard is to maximize the heat transfer to the oven back.



**Figure 48**

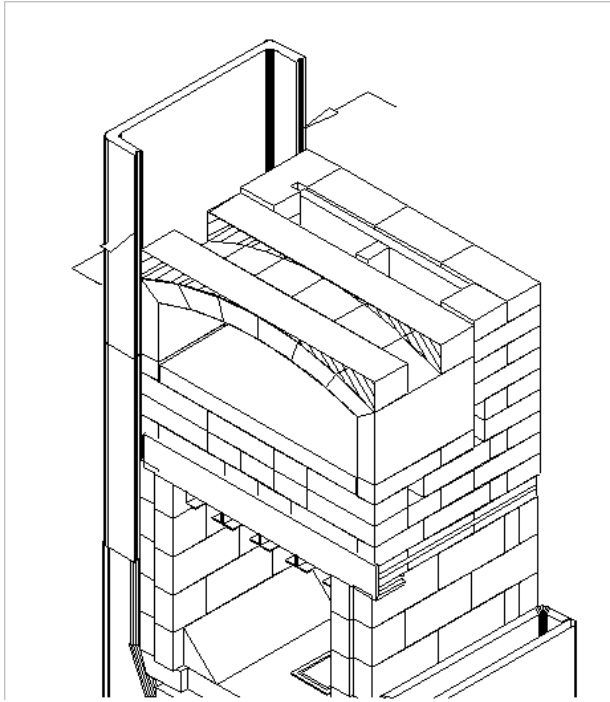


**Figure 47**

Rip firebrick split and insert into oven back notch to form retainer for millboard as shown.

Install fiberglass rope gaskets (supplied) inside oven. Use a screwdriver or similar tool to stuff the gasket into the space provided around the oven back insert, and around all 3 sides of the oven floor.

## Completing The Core

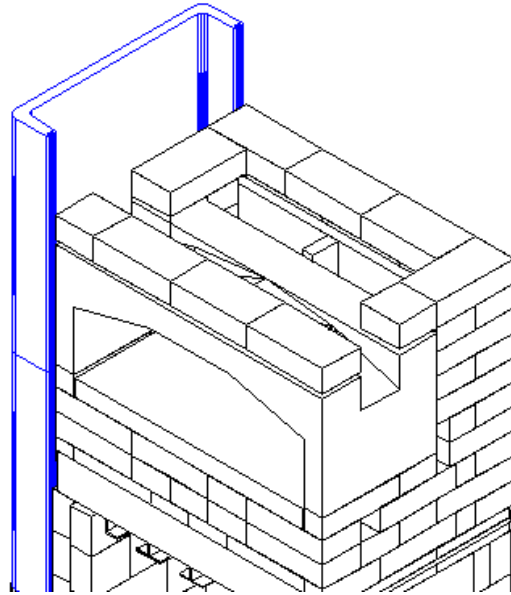


**Figure 49** Height adjustment

At this point, a height adjustment is necessary. Measure the height of two courses of firebricks (for example, 4-1/2"). Add 5" to this distance (for example, 9-1/2")

Place a pencil mark this distance (9-1/2" in this example, for this particular brick) from the top on all 4 channel ears.

The pencil mark indicates the top of the next course. If an adjustment greater than 1-1/4" needs to be made, insert a course of splits. If the adjustment is less than 3/4", use ordinary brick mortar. For 3/4" to 1-1/4", use castable refractory. Alternatively, you can cut the bricks to height on a brick saw.



**Figure 50**



**Figure 51**

In this example, a row of splits and a 1/4" mortar joint is required.

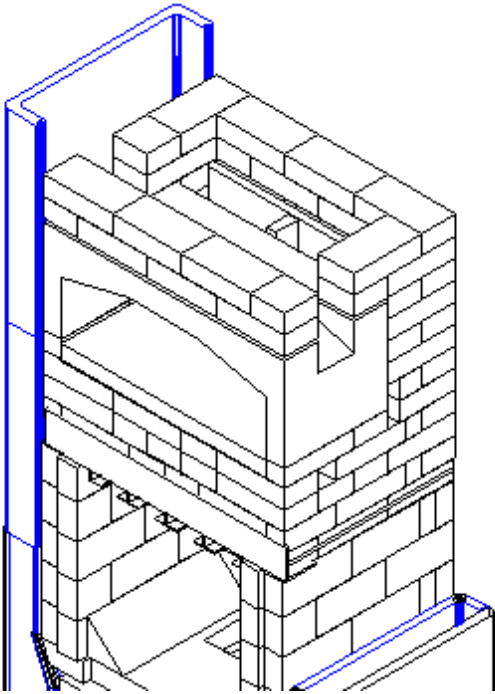
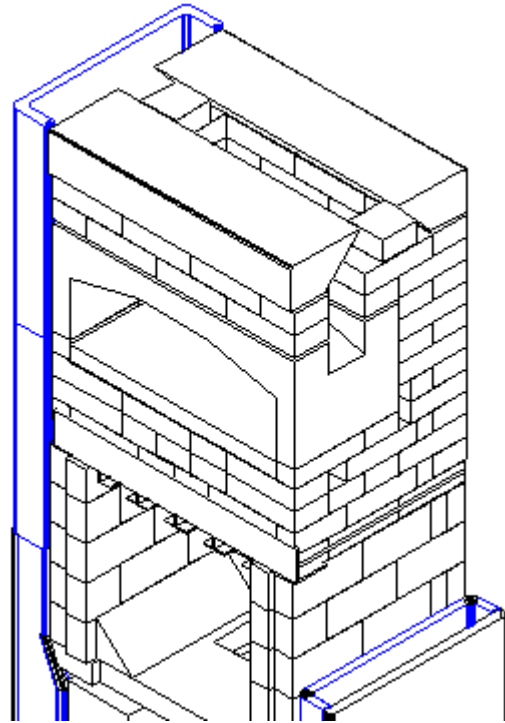
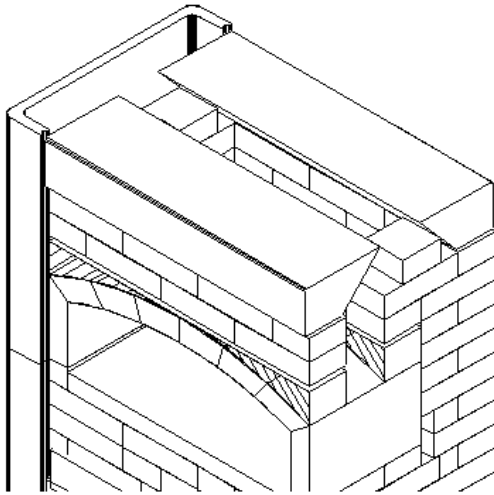


Figure 52

**Figure 53**

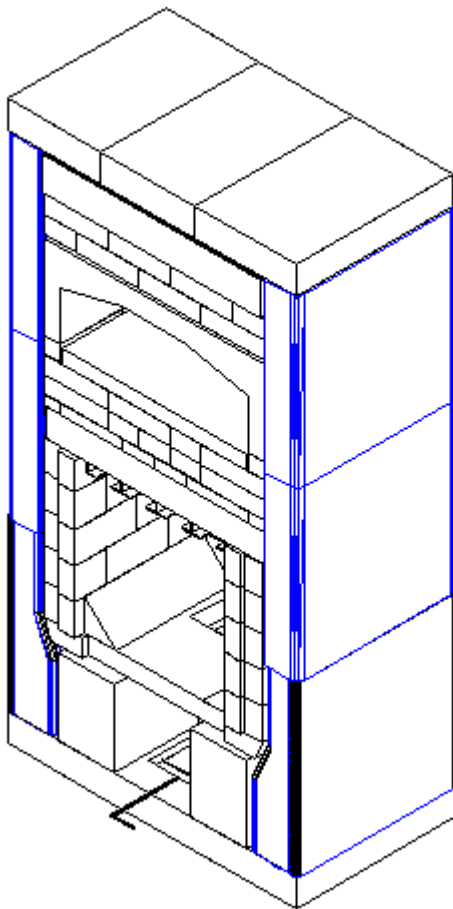
Install ceiling transitions. They should be 1/16" to 1/8" higher than side channels.

It is a good idea to install a temporary web strap around the channels, to avoid tipping a channel over and breaking it, while manipulating the ceiling transitions.



**Figure 54**

Install 2 half bricks as shown.



**Figure 55**

Install ceiling slabs. Use a helper, and set up adequate staging (foot planks). Install the slabs dry.

Using GE clear silicone, carefully seal all ceiling slab joints, particularly the shiplap joints and the bottom joint. If gap between slab and top of side channels is greater than 3/16", stuff with ceramic fiber first.

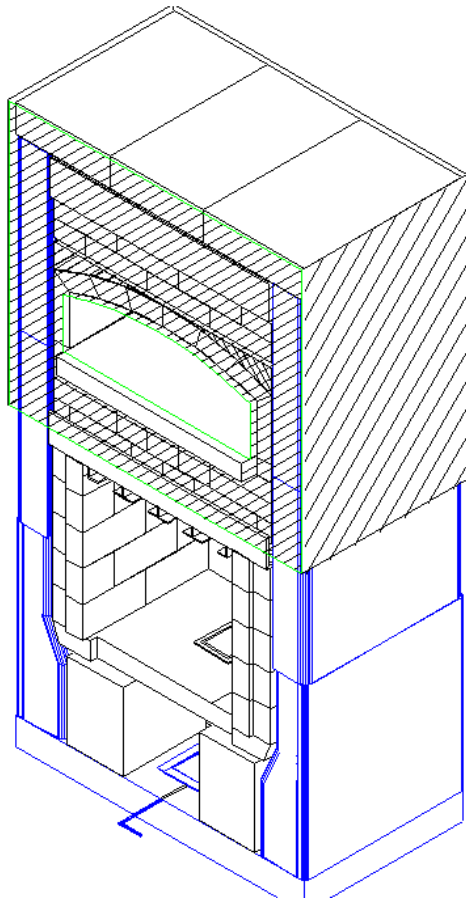
Next, check firebricks for full joints.

Next, check side channel gaskets and use silicone to tighten where needed.

(Note: the oven floor is shown projecting - ignore this (older version)).



## Fiberglass Slip Joint

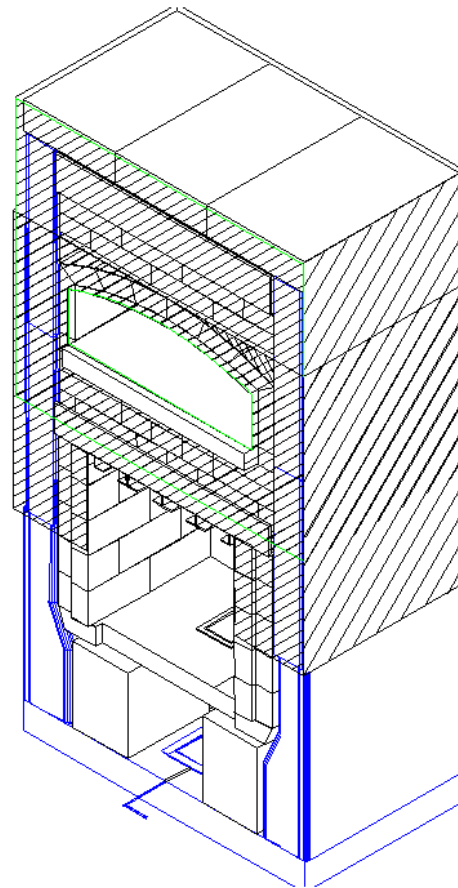


**Figure 56**

Next comes a double wrap of fiberglass matt to act as an expansion and slip joint. The mat is somewhat fragile, and releases glass fibres if handled too much - wear old clothes.

Two pieces of fiberglass are supplied -- a 38" wide piece and a 52" wide piece. Start with the 38" wide piece.

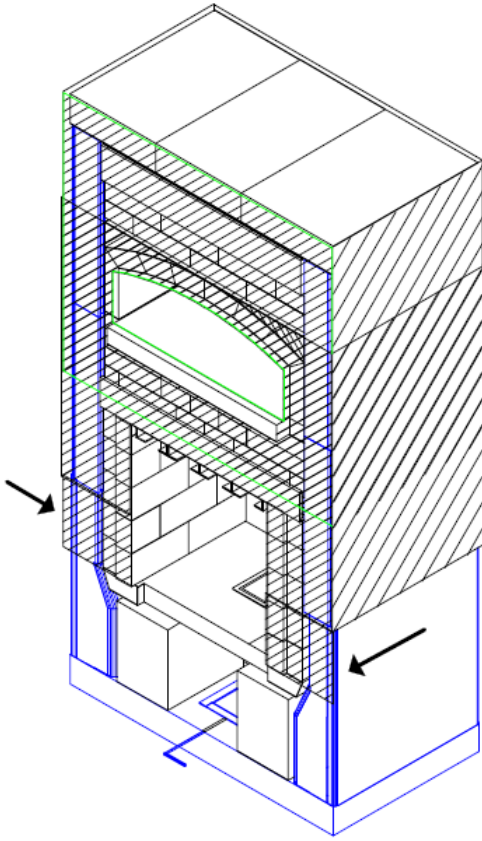
Quickly dab silicone approximately 4" - 6" o.c. over entire area indicated. Start at top of ceiling slab and go 38" down. Carefully unfold fiberglass mat and, with a helper, wrap around heater. Make sure mat goes all the way to top of ceiling slab. Have helper hold in ends in place, and go around heater, patting the mat onto the silicone.



**Figure 57**

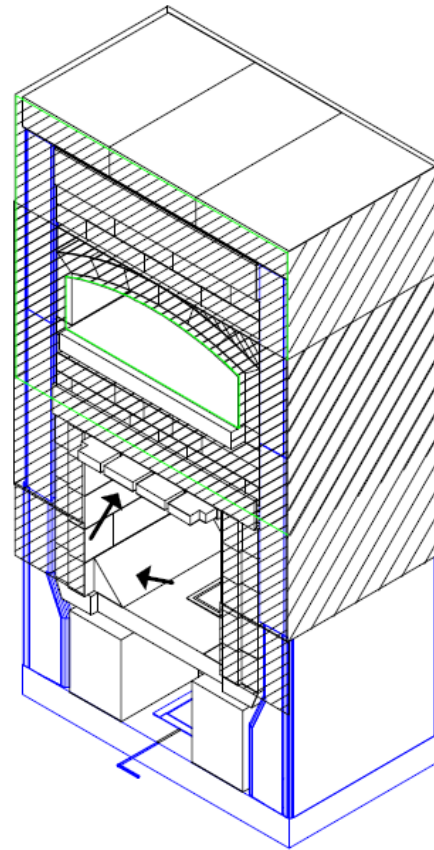
Trim to give approx. 4" overlap, and secure end with metal tape supplied

Second wrap of fiberglass mat is 52" wide, and also starts at top. Use same procedure as before. Trim around firebox and use offcuts to cover exposed firebricks at front. (Figure 58)



**Figure 58**

Add two additional pieces as shown.



**Figure 59**

Note location of firebrick split heat shields.

If not installed already, set sloped floor pieces onto a bed of refractory mortar, similar to setting a firebrick.