



**Review - particulate
emissions from
wood burners in
New Zealand**

**Prepared for the National Institute of Water and Atmospheric Research
by Emily Wilton
Environet Limited
www.environet.co.nz**

December 2012

Acknowledgements

The assistance of the following people in providing data and advice was greatly appreciated:

Jeff Bluett from Golder provided valuable comments on the history of the wood burner programme within New Zealand and technical matters relating to more recent test methods. Angie Scott from Environment Canterbury provided data from testing of wood burners in Christchurch and Nelson. Josh Fyffe from the Ministry for the Environment provided data from the testing of low emission wood burners in Tokoroa.

Executive Summary

Concentrations of particulate (PM₁₀) exceed National Ambient Air Quality Standards in many urban areas of New Zealand. Poor air quality is typically limited to the winter months when meteorological conditions conducive to elevated concentrations combine with increased emissions occurring as a result of solid fuel burning from domestic home heating. In most areas cord wood is the predominant fuel with pinus radiata (pine) being the most common type.

To assist with air quality management in urban areas the Ministry for the Environment introduced a design criterion for wood burners. New installations on properties less than two hectares are required to meet an emission limit of 1.5 g/kg of particles when tested to NZS 4013 and an efficiency criterion of 65%, from September 2004. The effectiveness of this management measure relies on the average real life emissions from these low emission burners being lower than the average real life emissions from older wood burners.

Research into real life emissions from both older and low emission wood burners has been carried out in New Zealand. This report summarises this research and compares approaches and results with international studies. Issues considered include emission limits, test methods, real life tests, impacts of fuel and innovative technology. Knowledge gaps are identified and future research is prioritised.

The average emission for low emission burners in New Zealand based on in home measurements where the fire has been operated by the homeowner in 36 households is 5 g/kg (wet weight). Similar testing of 12 households using older wood burners gave an average emission of 11 g/kg (wet weight).

Real life testing of particulate emissions from wood burners has been carried out in Austria, Italy and the United States. The approach to date has largely focused on laboratory testing using simulations of real life operation and tests to determine the impact of start-up (cold start) and the influence of poor operation and wood quality and type. Results from overseas testing indicate real life emissions less than 100 mg/MJ are possible (equivalent 1.5 g/kg for pine). However, results from New Zealand studies suggest simulations of real life emissions may significantly under predict emissions relative to operation by householder.

The top three research priorities for developing this work were identified as:

- 1) Further real life testing of low emissions burners would assist in the following areas:

- a. Evaluation of the extent to which more data might change the average emission factor for NES compliant burners.*
 - b. Further understanding of the distribution of data including deriving an emission factor for poor operation and the proportion of households likely to operate burners poorly.*
 - c. Evaluating regional differences or whether particular appliance types might perform better than others.*
- 2) A comparison of the advantages and disadvantages of the two methods used in New Zealand, and any other possible options, should be carried out before any further studies are undertaken.
- 3) Further research into fuel consumption rates nationally and factors influencing this. In particular, do older burners use more or less fuel than low emission burners?

Collaborating with international teams working in this area is also recommended to assist with the development of consistent methods and to promote achievement of mutual goals.

Contents

1	Introduction	8
2	Wood burners in New Zealand.....	10
2.1	Emission limits.....	10
2.2	Methods for measuring particulate	11
2.3	Testing of “real life” emissions from wood burners.....	12
2.4	Testing of variability in emissions in New Zealand.....	17
2.5	Factors influencing burner operation	19
2.6	Other burner information	19
2.7	Burner operation in New Zealand	20
2.8	Compliance issues – NES compliant burners	20
3	International Context	24
3.1	Emission Limits	26
3.2	Laboratory test methods	29
3.3	Real life testing of particulate emissions from wood burners	30
3.4	Innovative technology for reducing PM ₁₀	33
4	Historical research questions	36
5	Discussion	41
5.1	Impact of fuel type	41
5.2	Units for emission limits	41
5.3	Emission factors for wood burners	41
5.4	Research design	42
5.5	Research priorities	43
5.6	Collaboration with overseas organisations	44

6	References	48
	Appendix A: The big blue box test method	54
	<i>Sampler design</i>	54
	<i>Flue extension and primary diluter</i>	56
	<i>Analysis unit</i>	59
	Appendix B: Real life test data – summary statistics	62
	Appendix C: Comparison of laboratory simulations of real life and operation of householders in real life	64

1 Introduction

Concentrations of particulate (PM₁₀) exceed National Ambient Air Quality Standards in many urban areas of New Zealand. Poor air quality is typically limited to the winter months when meteorological conditions conducive to elevated concentrations combine with increased emissions as a result of solid fuel burning from domestic home heating.

In New Zealand solid fuel, most commonly wood, is burnt on domestic heating appliances for space heating. The burners are typically located in the living rooms and are either free standing or inbuilt (Figure 1.1). The terminology used for these burners in New Zealand is wood burners. Similar types of appliances overseas are typically referred to as wood stoves or chimney stoves. Across the whole of New Zealand about one quarter of households use wood for domestic home heating in their main living area (Wilton & Baynes, 2009). However, in many small towns wood burners are the most common heating method.

Other solid fuel burning appliances used in New Zealand are wood stoves (fired by wood but used for the purposes of cooking and include an oven), pellet burners and multi fuel burners. Pellet burners came onto the market in New Zealand in the early 2000s but have had limited uptake with around 1% of the population using this heating method (Wilton & Baynes, 2009). Multi fuel burners are burners that can burn wood or coal and include coal burners, incinerators, coal ranges and pot belly stoves. Around 8% of households in New Zealand use multi fuel burners. However, in areas such as the West Coast of the South Island and in Southland where coal is readily available they are the most common heating methods.



Figure 1-1: Examples of a typical New Zealand freestanding (left) and inbuilt (right) wood burner

This report summarises wood burner emissions research carried out in New Zealand including laboratory and real-life methods and results and compares these with international literature. Issues such as emission limits, test methods, real life tests, impacts of fuel, innovative technology and its effectiveness in reducing PM₁₀ are evaluated and the future goals for research are identified.

2 Wood burners in New Zealand

Early model wood and multi fuel burners were introduced into the New Zealand home heating market in the late 1970s. By the early 1980s they had become a popular heating method, favoured over the open fire because significant improvements in the energy efficiency meant more heat was available for space heating.

2.1 Emission limits

During the 1980s restrictions on emissions were limited. The first emission limits were introduced in 1988 in Christchurch under the Clean Air Act (1972) using the Clean Air Council (1987) provisions and required an emission rate of less than 35 grams of particulate per hour. A number of coal burners were approved during the 1980s including the popular “Juno” and other brands such as the Bosca, Rayburn, McKay and Bellmac.

In 1992 the joint New Zealand Australian Standard for wood burners was introduced. This standard specified a particulate emission limit of 5.5 kilograms of total suspended particulate per kilogram of fuel burnt. The test method was specified in AS/NZS 7402 and AS/NZS 7403 which was intended as a test method and designed for the purpose of replication of results rather than as an indication of how the burner would perform in real life. The emission limit was not mandatory in either New Zealand or Australia and was only adopted as a requirement in Christchurch from 1992 where it was selected to replace the previously used 35 g/hr rate by the then Canterbury Regional Council¹ and was applied to the burning of any solid fuel. One multi fuel burner (the Woodsman Matai - multifuel) was approved under this emission test regime. In 1999 NZS 7402 and 7403 were replaced with AS/NZ 4012 and AS/NZ 4013 which reduced the emission limit to 4.0 g/kg.

The Canterbury Regional Council reduced the particulate emission requirements for burners installed in Christchurch from 5.5 g/kg to 3 g/kg in 1997 and then to 1.5 g/kg in 2000. In 2002 this was further reduced to 1.0 g/kg despite scientific advice that there was no evidence that further lowering of the “test” criteria would result in lower “real life” emissions. An additional thermal efficiency criterion of 65% was also introduced in 2002.

A number of other Councils adopted emission limits (for example, Nelson City Council - 1.5 g/kg and 65% efficiency, Otago Regional Council – 3.0 g/kg and Auckland Regional Council 4.0 g/kg). Environment Canterbury and Nelson City Council both prohibited the installation of solid fuel burners in houses using non solid fuel options in Christchurch and Nelson effectively limiting the number of households that could use solid fuel. Some exceptions were made for low emitting pellet fuel burners in both areas.

¹ This was carried over from the Clean Air Act requirements for the Christchurch “Clean Air Zone” through the “Transitional Regional Plan” (TRP). Under the TRP changes to this emission limit for solid fuel burners could be made by public notice.

In 2004 the Ministry for the Environment introduced a particulate (TSP) emission limit of 1.5 g/kg and an efficiency criterion of 65% for all new installations of wood burners on properties with an area of less than 2 hectares from September 2005. This standard was applied under the National Environmental Standards as a design criterion for wood burners and does not apply to other fuels. In this report these burners are referred to as “low emission” burners.

It should be noted that the test criteria limits were not used as “emission factors” because the test method was not designed to replicate real life. Emission factors were typically around a factor of two higher than the test emission limit, e.g., an emission factor of 3 g/kg was used for appliances meeting an emission limit of 1.5 g/kg (Wilton & Smith, 2006).

2.2 Methods for measuring particulate

2.2.1 The test method - AS/NZS 4012 and 4013

The AS/NZS 4012 and 4013 test method is based on the use of a dilution tunnel and gravimetric sampling of a particulate sample collected from the diluted gas stream. The sampling commences only after the burner is hot so the test method excludes cold start emissions. Dimensional lumber (100 x 50 mm) with a moisture content of 16-20% is used and in New Zealand pinus radiata (pine) is used. Wood is placed in the burner on a bed of hot fuel. Measurements are taken at low, medium and high burn rates and an average of the three is reported. The efficiency of the appliance is determined by carrying out the complete testing procedure in a calorimeter room.

2.2.2 Applied Research Services Method for in situ measurements

The automated method for testing solid fuel burners in situ was established by Applied Research Services. It was first used in the sustainable management fund (SMF) burner testing collaboration (Scott, 2005) and subsequently used in Bluett, Smith, Wilton, & Mallet (2009) and Wilton, Smith, Dey, & Webley, (2006). The portable emissions sampler captures particulate emissions using a method based on Oregon Method 41 (OM41). This method is also known as the Condar Method (Barnett, 1985).

The sampling head includes a dilution system to dilute and cool the flue gas. This simulates the dilution and cooling that occurs when flue gases mix with ambient air and results in condensation of oily compounds such as polyaromatic hydrocarbons which can then be captured on the filter. Flue gases are drawn into a manifold through the sample probe. Dilution air is also drawn into the manifold through small holes in its face. The diluted gases are then drawn through two filters which collect the particulate emissions.

The sampler includes a sampling head, which captures the sample of particulates. In addition flue temperature is measured, flue gases are analysed continuously for oxygen and carbon dioxide content and the carbon dioxide content of the diluted gas stream is analysed. The sampler also contains gauges to monitor and set gas flows through the sample head and flue gas analysers,

canisters of drying agent to remove water vapour from the gas streams, a gas meter to quantify the sample flow and a vacuum sensor to monitor filter loadings. The sampler is interfaced to a laptop computer, which activates the sampling pump when the heater is operated and the flue temperature rises. The computer is also used to log data.

The sampling head consists of a stainless steel dilution manifold (length 100 mm, internal diameter 49 mm) fitted with two end caps. One end cap is fitted with a short probe with a glass insert. The probe is inserted into the flue so that the inlet is near the flue centre. Dilution air is admitted to the manifold via 12 x 1 mm diameter holes in the face of the end cap. The sample is collected on two 47 mm glass fibre filters (Gelman Type A/E Cat No 61631) mounted on two filter holders fitted to the other end cap of the manifold.

Apart from the probe and manifold assembly the sampling assembly is the same as used in AS/NZS 4012/3. As with NZS4013 two glass fibre filters are used to collect the particulate materials. The flue gas composition is also measured and is used to calculate the total volume of gas which has passed up the flue per kilogram of fuel burnt. The total emissions can then be calculated from rate at which material is collected on the filter and the dilution ratio.

A comparison of the emissions relative to NZS 4013 conducted by ARS was shown in Wilton & Smith (2006). This showed a good correlation between the two methods ($r^2 = .93$, NZS 4013 = 0.99 portable sampler).

2.2.3 The big blue box method

The “big blue box method” was designed by scientists at CSIRO to measure real life emissions from wood burners in Tasmania (Meyer, Luhar, Gillet, & Keywood, 2008). The measurement method is real time (one minute resolution) light scattering using a Dustrak (TSI Inc. St Paul, Mn USA) analyser. Particulate mass calibration is carried out weekly using gravimetric analysis of particulate collected on a filter. The size fraction collected is uncertain but likely to be small (less than $PM_{2.5}$ with a large proportion less than PM_1 (Ozil, Haas, & Trouve, 2007)) as the method involves metres of tubing which larger particles will impact on. The method is described in detail in Appendix A (Meyer et al., 2008).

2.3 Testing of “real life” emissions from wood burners

Initial explorations of “real life” emissions from wood burners were conducted in the laboratory during the 1990s and used the same measurement approach as specified by the test method with variance to the fuel quality, inclusion of cold start and changes to the fuel loading and airflow setting characteristics. The tests were conducted by Applied Research Services and results were provided to the Canterbury Regional Council (the client) as hard copies. No additional reporting of results was made although data were used to confirm emission factors used for wood burners in subsequent studies.

2.3.1 Testing of NES compliant burners

The first formal study of real life emissions from wood burners in New Zealand was done by Scott (2005) during 2003 and 2004 and included testing of six wood burners. The testing programme comprised of three stages. Initially, tests were carried out in the laboratory using an approach simulating real life operation. Secondly, the same types of appliances were sampled in the field using the same prescribed firing techniques as used in stage 1 with the same “merchant supplied” firewood. The third stage used the same appliances in the field but appliances were operated by the households using their own wood supply. Measurements of particulate matter, VOCs and PAHs were made during stage 1. During stages 2 and 3 measurements were limited to particulate matter. A survey was also done to ascertain how households operate wood burners. Results from this are detailed in section 2.7.

The report concluded that only the stage 3 results were meaningful in terms of real life operation but that they were “*not necessarily representative of low emission burners and as such emission factors could not be developed*”. Four of the six burners met an emission limit of 1.5 g/kg. The measurement method was the ARS in situ method described in section 2.2.2 and the tests approach included cold start emissions. The mean of 10.8 g/kg (expressed on a wet-weight basis²) suggested that the emission factor used in emission inventories at the time for low emission burners may have been many times too low. However, Scott (2005) noted that due to the small sample size of this study, it was not possible to identify a robust emission factor for low emission wood burners but did suggest that in a “real-life” situation some appliances may well produce emissions that are substantially higher than the “real-life” average emission factor of 3 g/kg.

In addition the testing undertaken in Scott (2005) indicates that approaches whereby simulations of “real life operation” may significantly miss the mark in terms of replicating real life operation. This is demonstrated in the difference between the stage two (operated in home by a laboratory technician simulating real life) and stage three (operated in home by the homeowners using their own fuel) measurements. For all but one appliance operation by the householder resulted in much higher emissions than the real life simulations. A comparison of these test results are shown in Appendix C. The study also found that moving from the laboratory to a field environment (in home) did not appear to significantly influence measured emissions. The author also suggested that the installation and appliance design characteristics of some appliances were more accommodating of sub-optimal modes of operation and unfavourable firewood characteristics, than some other appliances.

Further testing of NES compliant (those meeting an emission limit of 1.5 g/kg) was carried out by (Kelly, Mues, & Webley, 2007b) mostly using burners installed as part of a “warm homes” burner

² This was based on an average across all runs rather than an average of the households (average) emission factor. The latter approach has been used in subsequent studies and is used in Appendix B.

swap out scheme in Tokoroa³. Nine households were included in the study. The average emissions from these were reported as 4.6 g/kg (dry weight) and report a 95% confidence interval of 2.6-6.6 g/kg (Kelly et al., 2007b). Smith, Bluett, Wilton, & Mallet, (2009) obtained wood use data from the Tokoroa programme and calculated the equivalent wet-weight emission factor to be 3.6 g/kg.

In situ testing of 18 households using NES-authorized wood burners was undertaken in Nelson, Rotorua and Taumarunui during the winter of 2007 (Smith et al., 2009). The measurement method was the ARS in situ method described in section 2.2.2 and included cold start emissions. A total of 92 valid results were obtained. A mean wet-weight emission factor of 3.3 g/kg was derived. There was considerable variability in results from this study and the 95% confidence interval around the mean was 0.8–5.7 g/kg.

In 2009 further testing of NES compliant burners was carried out using the “big blue box” method (section 2.2.3) in six households in Christchurch (Bluett & Meyer, 2011a). Four of the houses had wood burners that met the Environment Canterbury 1.0 g/kg laboratory emission test standard and two houses had wood burners that met the National Environmental Standard 1.5 g/kg laboratory emission test standard. Particulate emission data were collected at one minute resolutions as well flue temperature, indoor temperature, indoor carbon monoxide, indoor relative humidity and wood use. In addition indoor particulate concentrations were measured at two households. Average emission factors were calculated for the wood burners monitored in the study as 7.3g/kg and a revised overall estimate of 4.3 g/kg (wet weight) was made based on all test data for NES compliant burners (Bluett & Meyer, 2011a).

2.3.2 Testing of older (pre 1994) wood burners

In winter 2005 an *in situ* emission-testing programme was carried out to test the validity of existing emission factors for older (pre 1994) solid fuel burners in Tokoroa (Wilton, Smith, Dey, & Webley, 2006). A total of 96 measurements were made from across 12 households. Households operated the burners as they normally would and used their own fuel. The measurement method was the ARS in situ method described in section 2.2.2 and included cold start emissions. The average emissions were 11 grams per kilogram (wet weight) and 14 grams per kilogram (dry weight) and compared favourably with emission factors of 11-13 grams per kilogram used in inventories for older burners in New Zealand.

2.3.3 Testing of pellet burners

Testing of pellet burners when operated in real life was carried out by (Kelly, Mues, & Webley, 2007b) using four pellet burners installed as part of a “warm homes” burner swap out scheme in

³ Six of the nine burners tested had been installed as a part of the Ministry for the Environment’s “Warm Homes” programme.

Tokoroa. The measurement method was the ARS in situ method described in section 2.2.2 and included cold start emissions. An average emission factor of 3.9 g/kg was derived. However, the authors noted that the result was skewed by one pellet burners which on further examination had “suffered from damage and incorrect operating procedures, which would have led to pellets smouldering in the firebox outside the burn pot and in the ash drawer” (Kelly et al., 2007a). Excluding the results from this pellet burner gave an average emission factor of 1.4 g/kg.

2.3.4 Summary

A number of studies have been carried out in New Zealand to measure real life emissions from domestic wood and pellet burners. The main focus for these investigations are emissions from NES compliant (1.5 g/kg) burners because of the need to ascertain the reductions in PM₁₀ that may occur through regulations targeting older burners, burner swap out programmes and natural attrition as older burners are replaced with lower emitting NES compliant wood burners.

Table 2-1: Summary of real life emission testing in New Zealand (homeowner operated)

Appliance type	Number of appliances tested	Location	Number of runs	Wet weight emissions (g/kg)	Reference
1.5 g/kg compliant burners	4	Christchurch/ Nelson	43	10.8	(Scott, 2005)
Burners >1.5 <3.5 g/kg	2	Christchurch/ Nelson	15	8.4	(Scott, 2005)
Pre-1994 wood burners	12	Tokoroa	96	11	(Wilton et al., 2006)
NES compliant burners (1.5 g/kg)	9	Tokoroa	50	3.6	(Kelly et al., 2007b) (Smith et al., 2009)
Pellet burners:	3	Tokoroa	28	1.4	(Kelly et al., 2007a)
NES compliant burners (1.5 g/kg)	18	Nelson Taumarunui Rotorua	92	3.3	(Smith et al., 2009)
1.5 and 1.0 g/kg	6	Christchurch	100	7.3	(Bluett & Meyer,

burners					2011a)
---------	--	--	--	--	--------

Particulate emissions for NES compliant burners for two studies (Kelly et al., 2007b; Smith et al., 2009) averaged around 3-4 g/kg while the other two studies (Bluett & Meyer, 2011b; Scott, 2005) gave emissions at least twice as high. These differences are unlikely to be explained by measurement method as within the higher emission studies, Scott (2005) used the ARS method and Bluett (2009) used the CSIRO method. The staged testing process undertaken by Scott also showed there was minimal impact of moving out of the laboratory into the home (by keeping testing regime and fuel supply constant) removing the possibility of some set up issues with measuring in-situ.

The large increase in emissions between the stage two and stage three tests done for Scott (2005) suggest that the differences between low and high real life emissions lie solely with how the burner is operated and the fuel that is used. To this end it seems reasonable to collate data from the different studies and to evaluate the distribution in particulate emissions between households.

Data for burners compliant with an emission limit of 1.5 g/kg (low emission burners) have been collated for this report to determine the average emission factor across households with NES compliant wood burners. The average emission across the 36 households included was 5 g/kg (wet weight). Table 2.2 shows the average results for the 36 households included in this evaluation.

Table 2-2: Average household particulate emissions for New Zealand real life testing

Year	Location	Study	Laboratory test - 4013 g/kg	Test emissions g/kg (wet)	Wood moisture content %
2009	Christchurch	(Bluett & Meyer, 2011b)	0.6	5.9	15%
2009	Christchurch	(Bluett & Meyer, 2011b)	0.8	5.5	17%
2009	Christchurch	(Bluett & Meyer, 2011b)	0.6	8.8	16%
2009	Christchurch	(Bluett & Meyer, 2011b)	0.9	17.7	23%
2009	Christchurch	(Bluett & Meyer, 2011b)	1.2	1.5	22%
2009	Christchurch	(Bluett & Meyer, 2011b)		4.5	23%
2007	Nelson	Smith et al., (2009)	0.6	0.8	18%
2007	Nelson	Smith et al., (2009)	1.2	1.1	14%
2007	Nelson	Smith et al., (2009)	0.4	0.4	16%
2007	Nelson	Smith et al., (2009)	0.6	0.9	16%
2007	Nelson	Smith et al., (2009)	0.9	1.0	15%
2007	Nelson	Smith et al., (2009)	0.6	4.5	21%
2007	Rotorua	Smith et al., (2009)	0.9	1.5	17%
2007	Rotorua	Smith et al., (2009)	0.9	1.2	16%
2007	Rotorua	Smith et al., (2009)	0.8	2.4	15%

2007	Rotorua	Smith et al., (2009)	0.9	2.7	14%
2007	Rotorua	Smith et al., (2009)	0.9	1.9	47%
2007	Rotorua	Smith et al., (2009)	0.9	2.3	20%
2007	Taumarunui	Smith et al., (2009)	0.9	1.3	51%
2007	Taumarunui	Smith et al., (2009)	0.8	2.3	25%
2007	Taumarunui	Smith et al., (2009)	0.8	9.4	32%
2007	Taumarunui	Smith et al., (2009)	0.9	20.5	29%
2007	Taumarunui	Smith et al., (2009)	0.8	2.2	29%
2007	Taumarunui	Smith et al., (2009)	0.9	3.7	35%
2006	Tokoroa	(Kelly et al., 2007b)	0.9	3.5	18%
2006	Tokoroa	(Kelly et al., 2007b)	0.9	3.8	17%
2006	Tokoroa	(Kelly et al., 2007b)		6.7	40%
2006	Tokoroa	(Kelly et al., 2007b)	0.9	3.5	18%
2006	Tokoroa	(Kelly et al., 2007b)	0.9	4.1	17%
2006	Tokoroa	(Kelly et al., 2007b)	0.9	2.7	10%
2006	Tokoroa	(Kelly et al., 2007b)	0.9	3.2	16%
2006	Tokoroa	(Kelly et al., 2007b)	0.9	2.1	12%
2006	Tokoroa	(Kelly et al., 2007b)	0.9	2.9	19%
2003/04	Christchurch or Nelson	(Scott, 2005)	0.6	10.0	16%
2003/04	Christchurch or Nelson	(Scott, 2005)	1.1	14.7	19%
2003/04	Christchurch or Nelson	(Scott, 2005)	1.2	5.5	21%
2003/04	Christchurch or Nelson	(Scott, 2005)	0.9	19.6	25%

A key concern highlighted in the 2007 testing is the potential variability in average emissions from NES compliant burners from different locations in New Zealand. It is uncertain whether some location specific factors are influencing emissions (e.g., different ambient temperatures may influence the amount of particulate that condenses) or whether the differences are a function of the small sample sizes or some other factor. The 2009 Christchurch study recommends that investigations into the potential for location specific emission factors from NES compliant wood burners be carried out (Wilton & Bluett, 2012b).

2.4 Testing of variability in emissions in New Zealand

An alternative approach to “real life” infield testing of a representative sample of households to derive emission factors is to attempt to simulate real life operation in a laboratory. Because there is no one way of operating a burner this involves testing of a range of factors that can influence emissions, and different combinations of these factors, to come up with an “emissions model”.

A limited amount of testing of variability was carried out in Scott, (2005) and results were quantified. Table 2.3 shows the changes in emissions for each of these variables based on the testing undertaken. Note that the relationships observed are for a limited amount of testing and some conflict with observations found in the Auckland testing of burners (Xie, Mahon, & Peterson, 2012).

While the original intent of Scott (2005) was the development of a conversion factor to estimate real life emissions based on NZS 4013 test results taking into account the variability in emissions associated with burner operation and fuel use, the author recommends further testing based on real life in-field tests (where burners are operated by households) for the purposes of deriving emission factors.

Table 2-3. Impact of operator and fuel variables on emissions and the proportion of householders in Christchurch operating in accordance with these variables (from Scott, 2005).

Characteristics	Impact of each variable on emissions - relative change from base case	Proportion of households using each variable type - "Typical" operation
Main wood burner setting		
Low	+36%	30%
Medium	0%	44%
High	+22%	26%
Wood size		
Large wood (1.5 to 3 kg logs)	+147%	33%
Small wood (<1.5 kg logs)	0%	67%
Wood moisture		
Wet wood (~27% wet weight)	+140%	1%
Dry wood (~11% wet weight)	-12%	91%
Moist wood (11<>27% wet weight)	0%	8%
Wood moisture		
Gum (eucalypt)	+23%	16%
Oregon (Douglas fir)	-26%	16%
Macrocarpa	+21%	21%
Pine	0%	47%

In Auckland, testing of emissions from wood burners was carried out in a laboratory from 2007 to 2009 with the intent of investigating the impact of variability on emissions to assist with the development of the Auckland Council's "Domestic Fire Emissions Prediction Model" (Xie et al., 2012). Three wood burners were tested (two new and one old) by using pine, blue gum and macrocarpa from wood merchants in the region. Each test burning cycle consisted of cold start, high burn and low burn. The other fuel parameters tested included moisture content (15%, 25% or 35% wet weight, representative of dry, damp or wet wood, respectively), cut (split or unsplit wood) and size (small or large log). A total of 31 combinations were tested and five tests were carried out for each combination. In total, the whole dataset contained 155 test cycles.

Results showed that wet wood increases the g/kg emissions by a factor of two and that emissions from high burn were lower than low burn or start up and that unsplit wood generates more emissions than split wood. The older burner was found to have slightly higher emissions than the low emission burners (Xie et al., 2012).

Particulate emissions from pine (6.4 g/kg) were found to be significantly higher than from blue gum (5.1 g/kg) but not macracarpa (4.8 g/kg) ($p > 0.05$, Mann Whitney). The average emission factor for the two low emission burners was reported as 5.2 g/kg. The average emission factor for the higher

emission burner was 6.5 g/kg (Xie et al., 2012). It is uncertain whether the emission factor has been weighted based on the surveyed operation of burners across Auckland. The authors do note that care should be taken with interpreting the results owing to the small number of burners tested (three).

2.5 Factors influencing burner operation

An evaluation of the factors influencing burner operation has been carried out for a number of the real life emission testing programmes carried out in the field.

In the 2005 study of older burner emission factors in Tokoroa, the main factors influencing emissions were average flue temperature and flue oxygen. Operational aspects that influenced these variables were kilograms of fuel burnt, fuel moisture content, air flow setting, and number of pieces and weight of wood used (Wilton et al., 2006).

The impact of operational influences on emissions was examined again for the 2007 emission testing in Nelson, Rotorua and Taumarunui (Wilton & Bluett, 2012a). The key variables impacting on particulate emissions were found to be wood moisture, flue temperature, and oxygen. These explained 67% of the variability between households. Of these, wood moisture was the most significant accounting for 43% of the variability in particulate emissions. The majority (72%) of households in the survey did not appear to increase their fuel consumption when the daily temperature decreased. Four households in Nelson and two households in Rotorua showed a good correlation between outdoor temperature and fuel consumption, with the latter increasing when temperatures decreased.

2.6 Other burner information

The focus of the 2009 emission testing in Christchurch was to evaluate a diurnal profile for PM₁₀ emissions from domestic home heating, to measure the weight of wood used by householders to heat their homes, to assess the impacts of wood burner use on indoor temperature, relative humidity, CO and PM₁₀ and to investigate factors that influence the start-up of domestic wood burners.

Flue particulate data were collated to give an average temporal profile of emissions from domestic home heating. This was a major advancement in our understanding of daily variations in emissions from wood burners and has been used to give a better diurnal emissions profile for atmospheric dispersion modelling (e.g., Gimson, 2012).

The average daily fuel consumption for across the six Christchurch households in Wilton & Bluett, (2012a) was found to be 15.4 kilograms per day. This compares with an average of 27 kilograms per household per day across Nelson, Rotorua and Taumarunui (Wilton & Bluett, 2012a). Differences may be due to lifestyle factors and ambient winter temperatures.

In Wilton & Bluett, (2012a) start-up times were evaluated to determine if variables such as ambient temperature or room temperature were key determinants of the use of the wood burners. No

relationships between these variables were found and it was assumed that individual lifestyle factors, such as work schedules, had the greatest influence on wood burner start time.

2.7 Burner operation in New Zealand

Some information has been collected on how burners are operated in New Zealand. A survey of Regional Council websites, a general web search and contacting air quality experts at Councils revealed the following sources of information relating to wood burner behaviour in New Zealand:

In 2003 a phone survey was carried out for 513 households in Christchurch to determine the type and volume of wood used and how they operated their burners (Lamb, 2003b). The study found that 49% of households got some or all of their wood free of charge and that around half of the households used pine. The majority used their wood burner 5 days a week or more and 70% operated their wood burner for 4 hours or more on weekday and 85% for 4 hours or more during weekends. Most people thought it took 10 minutes or less for a fire to establish and generally operated their wood burner on maximum air setting for this time. The proportion of households using each air setting is 25% low, 46% medium and 29% high⁴. Around half of the households did not adjust the air setting when adding more wood to the burner. Around 26% of households banked the fire down at night (refuelled and turned the fire down to a low air setting). It is likely that this is lower than for other areas of New Zealand because the early introduction of stricter emission limits in Christchurch would mean fewer appliances would be able to be banked down for an overnight burn. An earlier panel style survey of 216 households in Christchurch found that 91% have a covered wood pile (Lamb, 2003a).

A mail survey carried out in a selection of towns in the Otago Region in 2006 found that 56% of households with a wood burner would bank it down overnight (Advanced Business Resources, 2006). The main reasons for banking down the fire was to keep the room warm overnight (94%) and to make it easier to start in the morning (50%). Other reasons (7%) included to keep the whole house warm, to stop the pipes from freezing, to dry the washing, to keep the water heated on the wetback and to keep the power bill down. Around 12% of households said they didn't bank their fire anymore in an attempt to reduce air pollution.

2.8 Compliance issues – NES compliant burners

In 2007, the Ministry for the Environment carried out a performance review on a random sample of NES compliant wood burners (Ministry for Environment, 2007). The review comprised of an in-store examination of models of burners for design consistency with the “authorised” model. Of the 35 burners included in the review, 57% failed. The performance review included models that had already been installed in Tokoroa as a part of the Tokoroa real life emission study (Kelly et al., 2007b). Of the burners included in both the performance review (Ministry for Environment, 2007)

⁴ If the non-respondents or households that responded with “varies” are omitted – these totalled 11% of households.

and emissions testing (Kelly et al., 2007b) only one was found to have failed. This failure was of a minor nature and would not have impaired the performance of the burner.

As a result of the non compliance observed in the 2007 study a follow up audit was conducted in 2011. A total of 88 burners had measurements taken to assess compliance relative to design specifications. Just of 50% of the burners tested had compliance issues, although these were noted as not being “severe” (KPMG, 2011). A number of areas were identified where future improvements could be made to the assessment process or testing regime for wood burners. These were:

- Manufactured tolerances: Tolerances that are not specific to emissions or efficiency performance may not align with the objectives of the audit programme.
- Appliance measurements: Inconsistency in measurements in test reports and design drawings make assessment more difficult.
- Wood use guidance: Inconsistent guidance over the use of hard/soft woods used in burners.
- Test reporting: Generally test reports did not contain all information required per the testing standards. This usually related to a lack of design drawings and baffle information (KPMG, 2011).

A similar project carried out in Australia found a large proportion of burners available at retail stores that had been approved under AS/NZ 4013 did not meet the design specifications of the authorised burners (Australian Department of Environment and Heritage, 2004b). The emission limit specified in AS/NZ 4013 is 4.0 g/kg for particulate. Results of the study found that

- 58% (7 out of 12) of wood burners failed to meet AS/NZ 4013 particle emission limits
- 55% (26 out of 47) of wood burners had one or more serious design faults that could affect performance
- 72% (34 out of 47) of wood burners had one or more labelling faults that could affect emissions performance

In addition laboratory testing was carried out for emissions to determine if noncompliance with design characteristics was a good indicator of noncompliance with emissions. All seven of the wood burners that failed to comply with AS/NZ 4013 emission limits had one or more serious design faults. However, one of the five burners that was compliant with emissions testing had serious design faults. The most common engineering design fault associated with emissions and engineering design non-compliance was primary air inlets that were smaller than originally specified in design drawings. The report concludes that further auditing is required to monitor the compliance of wood burners available for retail sale (Australian Department of Environment and Heritage, 2004b).

A follow up action plan to address non-compliance issues was developed by the Australian Government and industry in recognition that the degree of non-compliance found in the audit program was serious, and that concerted action was required to ensure future compliance with the Australian Standard (Australian Department of Environment and Heritage, 2004a).

The following actions were agreed by Government and the Australian Home Heating Association to address the major issues arising from the Audit Program report:

AS/NZS 4013 certification test procedures

- *Future certification will involve a two-stage process, comprising of a complete AS/NZS 4013 test on a prototype, followed by design specification/labelling test on a factory warehouse model.*
- *Certification is only to be granted after the factory warehouse model passes the design specification/labelling test.*

Certification process documentation

- *The certification process will be comprehensively documented to identify procedures that manufacturers need to follow before certification can be granted. The documentation will incorporate the new certification procedures, as outlined above.*

Follow-up audit program

- *A voluntary follow-up audit program will be conducted to audit all certified models over two years. This program will be jointly administered by the Australian Government (on behalf of participating jurisdictions) and the AHHA.*
 - *Non-AHHA affiliated manufacturers will be requested to participate in the audit program.*
 - *States and Territories may conduct mandatory audits to assess compliance against regulatory requirements, particularly in cases where manufacturers are unwilling to participate voluntarily.*
- *The audit will consist of a comparison of each woodheater model against design drawings submitted for the initial certification testing, and an assessment to determine if the model complies with AS/NZS 4013 labelling requirements. Testing will be conducted at manufacturers. warehouses (rather than at retailers. premises). The audit will also include three full emissions test over two years, to be conducted on randomly selected models, which will also be selected from manufacturers. warehouses.*
- *If woodheaters fail the initial audit, they will be reaudited at the manufacturer.s expense. If the model also fails the second audit, then an emissions test will be carried out at the manufacturer.s expense.*
- *Certification will be immediately suspended if any non-conformances that can affect emissions performance are revealed during the audit (including labelling), until it is demonstrated that non-conformances have been rectified. This will be established by a subsequent audit from models chosen through the same procedure as the initial selection.*
- *Funding responsibilities under a follow-up audit program will be as follows:*
 - *Testing costs will be borne by manufacturers;*

- the AHHA will fund the costs for emissions testing; and
- administration costs will be shared between governments and the AHHA.

Anti-tampering provisions

- Governments and the AHHA will write to Standards Australia to request the inclusion of anti-tampering provisions in the Australian Standard (AS 3869 - Design and Construction), so that it is more difficult for operators to modify factory-set appliance operating parameters (eg minimum air flow settings).

Non-compliant woodheaters already sold and installed

- Government environment agencies may refer the issue of non-compliant woodheaters already sold and installed to the consumer protection agencies within their jurisdiction.

3 International Context

The European Union have set two limit values for particulate matter (PM₁₀) and a PM_{2.5} 2015 limit for the protection of human health: the PM₁₀ daily mean value may not exceed 50 µg/m³ more than 35 times in a year and the PM₁₀ annual mean value may not exceed 40 µg/m³. Figure 3.1 shows that many countries in Europe do not comply with daily limit (European Environment Agency, 2012). Figure 3.2 shows that commercial, institutional and domestic fuel combustion is the major contributor to primary PM₁₀ and PM_{2.5} emissions across Europe (European Environment Agency, 2012).

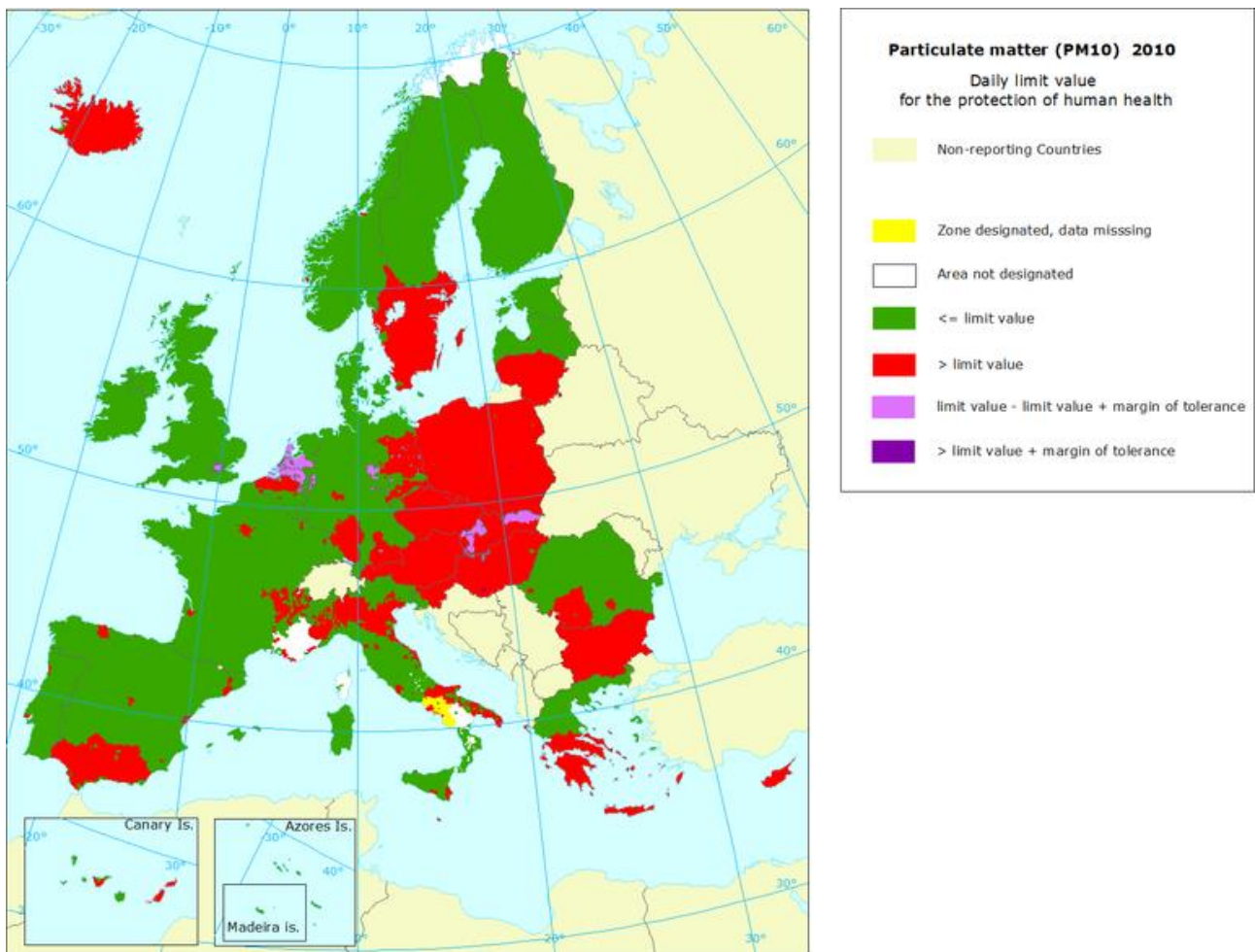

Figure 3-1: Compliance with the European Union Limit for daily PM₁₀ across Europe in 2010

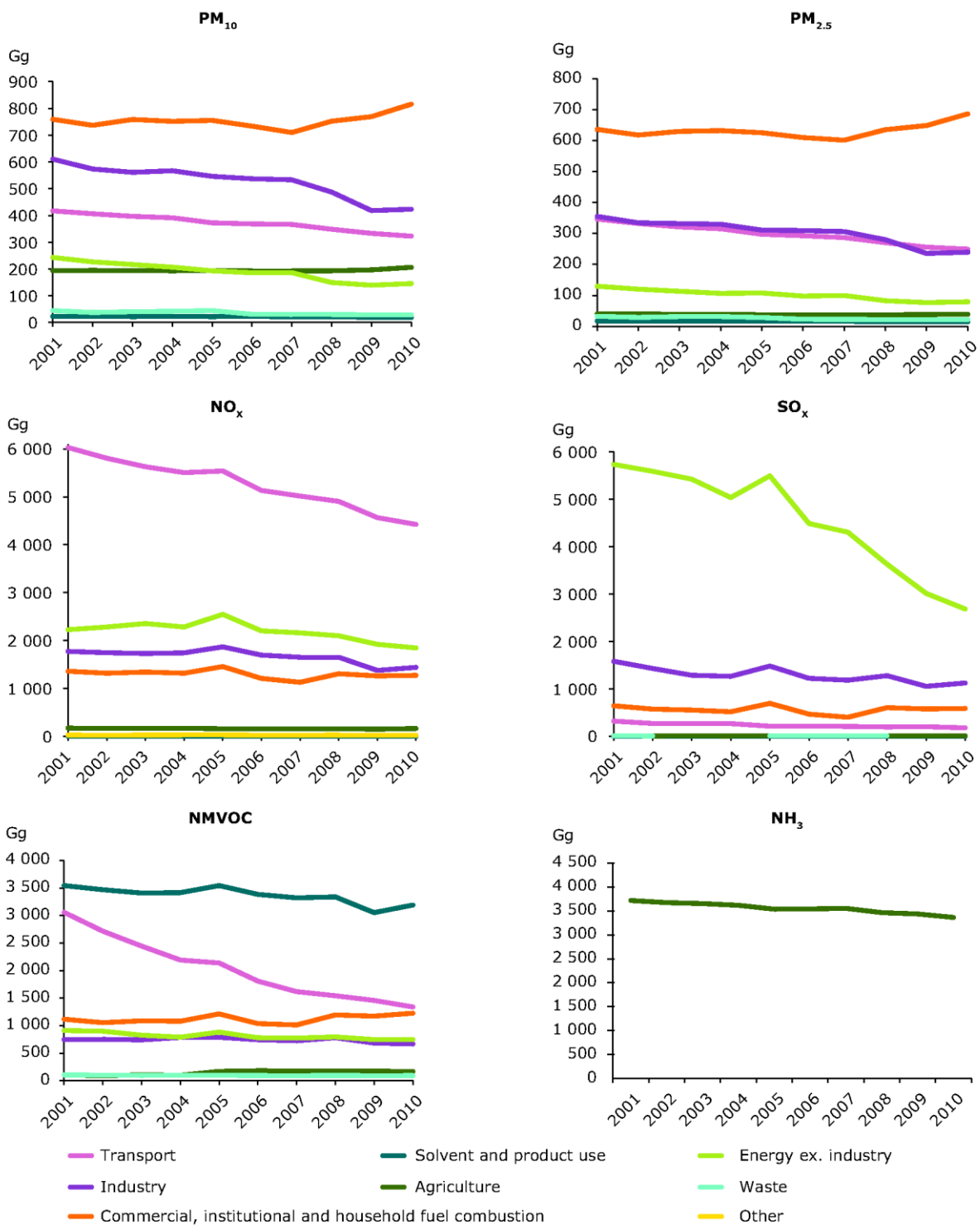

Figure 3-2: Contributions of sources to contaminant emissions across Europe

Wood burners or wood stoves, as they are more commonly referred to internationally, are used for domestic home heating across Europe, in North and South America, in Canada and Australia. .

In Austria domestic wood combustion was responsible for around 24% of the PM₁₀ in 2008, with industry being the greatest contributor at 27% and motor vehicles 23% (Oberberger & Mandl, 2011). In Lombardy Italy residential wood burning contributes 27% of the particulate emissions and in Milan the contribution is 12% (Angelino et al., 2008).

In Denmark residential heating systems accounted for 71% of the annual PM_{2.5} emissions in 2009 (Nielsen et al., 2011), with wood use in stoves and boilers being the dominant contributor (Oberberger & Mandl, 2011). Other sources of PM_{2.5} include motor vehicles (12%) and other mobile sources (10%). The majority of the motor vehicle emissions were from exhaust (64%) and the other mobile sources was dominated by off-road vehicles and machinery used in the industrial sector and in the agricultural and forestry sector. A 35% increase in PM_{2.5} emissions occurred from 2000 to 2009 as a result of increasing fuel consumption in the residential sector (Nielsen et al., 2011).

In Canada wood fuel is used by around 3.5 million households as a source of heat. Consequently residential wood combustion contributes around 30% of the annual anthropogenic particulate emissions (Oberberger, & Mandl, 2011). In the United States the contribution of residential wood burning to PM_{2.5} emissions is less significant at around 7% overall (Wang et al., 2011). Residential wood combustion was estimated to contribute around 26% of the primary PM_{2.5} in Finland, 69% in Norway and 42% in Sweden in 2004 (Karvosenoja et al., 2004).

3.1 Emission Limits

There are a number of different test standards for the testing of wood burners/ wood stoves used internationally. Different standards require outputs in different units. The most common units used in Europe are mg/MJ with the MJ referring to the calorific value of the fuel (i.e., heat in). In the United States, Chile and in the United Kingdom certification is based on a grams per hour unit.

An evaluation of the different emission requirements internationally for particulate emissions from wood burners was conducted by Wilton (2012). This found that in Europe countries such as Austria, Germany, Switzerland, Denmark and Ireland had emission limits for new wood burner installations (Oberberger, & Mandl, 2011) and limits existed in the smoke control areas of the United Kingdom (Department for Environment Food and Rural Affairs, 2012). In Canada there is no federal regulation relating to emission limits. However some provinces have developed provincial regulation restricting use of new woodstove installations to meet the Canadian Standards Association (CSA) and United States Environmental Protection Agency, (US EPA) emission limits (Li, 2012). Tables 3.1 to 3.3 show the summary of information collated in that report which includes some voluntary Eco Labels (grey shaded columns). It is noted in Wilton (2012) that the terminology for burners differs between areas and some interpretation was required. Consulting the original documentation or summaries such as (<http://www.ieabcc.nl/publications/Filter-study-IEA-final-version.pdf>) is recommended if a more specific understanding is required.

Table 3-1: Summary of wood burner particle emissions standards for European Countries (from Wilton, 2012)

	Austria standard mg/MJ	Austria Umweltzeichen label	Denmark	UK (DEFRA)	Nordic Swan⁵	Ireland	Sweden p-marking voluntary	Switzerland	Germany - 2011	Germany - 2015
Pellet boiler	60 mg/MJ	15 mg/MJ	72.7 mg/MJ		40 mg/MJ automatic feed	100 mg/MJ		27 mg/MJ	40 mg/MJ	27 mg/MJ
Pellet burner		30 mg/MJ	50 mg/MJ				66.7 mg/MJ	27 mg/MJ	30 mg/MJ	20 mg/MJ
Wood log boiler	60 mg/MJ	30 mg/MJ	72.7 mg/MJ		40 mg/MJ automatic feed 70 mg/MJ manual feed	100 mg/MJ		33 mg/MJ	40 mg/MJ	27 mg/MJ
Wood log stoves	60 mg/MJ	30 mg/MJ	50 mg/MJ	5 g/h and 100 mg/MJ (.1g per .3 kW)		100 mg/MJ		50 mg/MJ for room heaters. 60 mg/MJ for residential stoves	40 mg/MJ	27 mg/MJ

⁵ Swan label is eco label for Denmark, Finland, Norway and Sweden and is a voluntary scheme

Table 3-2: Summary of wood burner particle emissions standards for USA and Canada (from Wilton, 2012)

	Canada	USA (excl Wa)	Washington State
Any appliance no catalytic converter	137 mg/MJ and 4.5 g/hr	7.5 g/h	4.5 g/h
Any appliance with catalytic converter	137 mg/MJ and 2.5 g/hr	4.5 g/h	2.5g/h
Indoor central heating	400 mg/MJ		

Table 3-3: Summary of wood burner particle emissions standards for Chile

	Chile
Santiago	2.5 g/hr
Temuco	1.5 g/hr
Other locations (from 2013)	
Up to 8kW	2.5 g/hr
8-14 kW	3.5 g/hr
14-25 kW	4.5 g/hr

3.2 Laboratory test methods

Laboratory test methods have been available in the United States since the 1970s although the methods have changed over this time (Millichamp & Wilton, 2002). The current test methods for USEPA certification are methods 5G and 5H using specifications of Method 28 for operational procedures. Method 5G specifies the operation of a dilution tunnel and uses isokinetic sampling. Method 5H provides for direct sampling from the chimney with flow rates measured using a tracer gas injection system. Other methods used in the United States for various applications include Virginia Polytechnic Institute (VPI) sampler, Automated Woodstove Emissions sampler (AWES), Emission Sampling System (ESS).

The European Committee for Standardisation (CEN) has established a technical committee (TC 335: Solid Biofuels) to develop technical standards (TSs) for solid biofuels for the European Union. Over time the CEN/TSs for solid biofuels are being revised and upgraded to Euro Norms (ENs) displacing all other national standards across the EU (e.g., ONORM & DIN). They are also being used as the basis for new ISO standards (ISO/TC 238). The following ENs relating to solid fuel heating exist, but these do not include specifications for particulate emissions:

- EN 12815:2001, Residential cookers fired by solid fuel – Requirements and test methods
- EN 13229:2001, Inset appliances including open fires fired by solid fuels – Requirements and test methods
- EN 13240:2001, Roomheaters fired by solid fuel – Requirements and test methods

The CEN/TS for wood burners is specified in CEN/TS 15883:2009 and agreement on whether the specifications were suitable for an EN standard should have been made by March 2012. While CEN/TS 15883:2009 includes measurement methods for other contaminants it specifies that for particulate and dust emissions, the national documents of those countries that have a test method are reference methods while those countries that do not have a test method can choose from one of the methods listed. The listed test methods include an Austrian and German method, the Norwegian particle test method and the UK particle test method. Of these the Norwegian particle test method includes a dilution tunnel for the capture of condensables and the UK method has a dilution tunnel option. The Austrian and German method (including the method and criteria referred to as DIN plus) does not include measurement of condensables.

The need for a common European method is endorsed by the standardisation groups CEN/TC 577 and CEN/TC 295 and a common research project EN-PME-Test has been established to do this (Obernberger, & Mandl,., 2011).

3.3 Real life testing of particulate emissions from wood burners

Testing of wood burners under simulations of real life operating conditions has been carried out in the United States (e.g., Houck, Pitzman, & Tiegs, 2008), Canada (Li, 2012), Austria (Keltz, Brunner, Obernberger, Jalava, & Hirvonen, 2010; Schmidl et al., 2008, 2011; Kistler et al., 2012), Italy (Angelino et al., 2008) and Germany (Schon & Hartmann, 2012). Kocbach Bølling et al., (2009) summarise emission factors for different appliance types across Europe which includes a range for modern wood stoves of 34-330 mg/MJ compared with 50-2100 for conventional wood stoves and 160-190 mg/MJ for open fires.

Comparison of real life emissions data across the different studies however, is difficult owing to differences in methodology and measurement method. In addition the predominant approach involves testing to a prescribed method that attempts to simulate real life (either in the field or in the laboratory) as opposed to actually measuring emissions from operation by laypersons in the field. Scott, (2005) shows a large increase in particle emissions when comparing infield simulation of real life versus operation by a layperson.

Differences in the methods undertaken in some of the key international studies is summarised in Wilton, (2012) in a report aimed at identifying best international wood burning technology for producing low real life emissions of particulate. The studies examined in detail in that report were Keltz et al., (2010), Schmidl et al., (2008), Schmidl et al., (2011) and Houck et al., (2008). Relevant variables from these and other international research into real life emissions from wood burners are summarised in Table 3.4.

Table 3-4: Summary of real life testing studies of wood burners

	Keltz 2010 Austria	Schmidt 2008 Austria	Kistler 2012 Austria	Schmidt 2011 Austria	Houck 2008 United States	Angelino 2012 Italy	Li 2008 Canada	Schon 2012 Germany
Attempt to simulate of real life operation in the laboratory (L) or in field (IF)	L	L	L	L	L (possibly some IF)	L	L	L
Examine the impacts of fuel type, quality or loading on emissions	N	Y	Y (>10 species plus pine cones, pine needles, dry leaves)	Y (beech, oak, spruce, briquettes)	Collation of range of US studies	Y (beech wood, black locust)	N (white oak, 17-20% moisture)	Y (size and loading, only beech wood)
Examine the impacts of airflow setting on emissions	N	N	N	Y	Y	Y	N	N
Include cold start conditions	Y	Y	Y	Y	Y (and hot start)	Y	Y	
Capture of condensable component and maximum temperature of sample at measurement	Y (40°C)	Y (30 °C)	Y (near ambient)	Y	Y (32 °C)	Y	Y	Y (50 °C)
Number of batches of wood burnt (and weight of wood each load)	6 (1.6 kg)	1 (10 kg)	2 (1.3 kg)	3	Collation – no set method	4-5 (not specified)	1 (total 13.4-18.5 kg)	4-5
Test method	generally followed the set up in EN 13240	Gravimetric Not continuous sampling 3 x 2 minutes	Gravimetric (PM ₁₀ & PM _{2.5})	Gravimetric. Modified EN 13240 to replicate more real life type operation	All Method 5G	(method 5G) + optical for real time	Not specified but probably 5G as done by OMNI	Gravimetric
Particulate emissions	Tests on PM ₁ Wood burner 47 mg/MJ, Tiled stove 30 mg/MJ,	n/a – not continuous sampling	Average across fuels of 67 mg/MJ for modern wood stove.	90 mg/MJ (one simple one modern design)	Median 3.23 g/kg Range 0.64 g/kg – 35.7 g/kg (modern burners)	First hour 409 mg/MJ 89 mg/MJ	8.9 g/kg (older burners)	

Many of the studies look at the impact of changing variables such as wood type, moisture content, loading regimes, fuel size and operational settings. The purpose in many of the studies was to gauge the variability in emissions that can occur, rather than to derive emission factors using a range of operating parameters.

The differences in average emissions across a wide range of wood species common in Europe was investigated in (Kistler et al., 2012). European larch and black poplar gave the lowest emissions for a modern wood burner of around 20 mg/MJ. Highest emissions were found for sessile oak (202 mg/MJ), black pine (101 mg/MJ) and silver fir (100 mg/MJ).

In Schmidl et al., (2008) wood type influenced the length of time to reduce start up emissions with spruce emissions decreasing by almost a half by 10 minutes (compared with emissions at 2 minutes) and beech emissions increasing by almost 20% at 10 minutes. In contrast, Angelino et al., (2008) reported high particulate matter during start up for the first 3-6 minutes using Beech wood and Black Locust.

In Schon & Hartmann, (2012) the impact of varying log size differed across the three burners tested although the same patterns were generally observed. Particulate emissions were at least twice as high when small log sizes were used (5cm x 5cm x 25cm) compared with larger wood pieces (9cm x 9cm x 25 cm). The use of the smallest logs resulted in an intensive combustion initial phase with rapid release of volatiles followed by short residence time of the flue gases in the combustion chamber. Reloading with only one single log and overloading the burner also generally resulted in high particulate emissions (Schon & Hartmann, 2012). It is noted that the impacts varied, sometimes significantly with different burner models. This observation is important when considering “emission model” methods for deriving emission factors as it highlights the specificity of the results to the burners included in the model.

Table 3.4 shows that the range of dilution sampling temperatures is typically a maximum of 30-50 °C. Because both particulate and vapour emissions from wood burners include low molecular weight organic compounds changing dilution tunnel temperatures will shift the partitioning between vapour and particulate phases. The impact of this can be significant and has been demonstrated in other situations such as the monitoring of PM₁₀ using heated inlets in wood smoke environments (Bluett et al., 2007). Consistency in the sampling temperature would be of value. In real life ambient temperatures will be much less than 30 °C when wood burning is carried out. Adjustments to emission factors may be therefore required.

The inclusion of cold start emissions in the derivation of emission factors seems implicit. The average wood burner length of use for the United States is reported as being 4.8-

5.8 hours. This means that most burners are regularly being started from cold and therefore inclusion of cold start emissions is important in terms of replicating real life operation. However, the Houck et al., (2008) also noted that 44% of households used their burners for more than eight hours and that for these burners hot start-up scenarios might be common. In Angelino et al., (2008) cold start emissions were responsible for around 30% of the emissions across the total cycle. The prevalence of cold starts is likely to have increased in New Zealand since the introduction of the NES design criteria for wood burners in 2005 as a result of changes to the design of burners to limit the low burn ability.

Field studies show that emissions from both non-catalytic and catalytic burners increased with use and that some heaters showed physical deterioration (Houck et al., 2008). The impact of on-going degradation on particulate emissions for low emission burners in New Zealand may need to be characterised for the purposes of maintaining compliance with the NES for PM₁₀.

Colder climates may result in lower emissions owing to greater use of higher burn rates and more common “hot start” scenarios.

3.4 Innovative technology for reducing PM₁₀

A review of the best technology available internationally (excluding New Zealand and Australia) for achieving low real life particulate emissions from wood burners was carried out by in 2012 for Environment Canterbury (Wilton, 2012). Technology identified included innovative wood burner designs and secondary technology for reducing particles in the flue.

3.4.1 Innovative wood burner designs

Six key wood burner brands with innovative technology were identified in Wilton, (2012). Test data for these burners is not necessarily directly comparable to methods used in New Zealand. Limited real life testing has been carried out for these burners. Real life test data reported in this section are comparable to New Zealand test methods. Note that the mg/MJ units refer to MJ (heat in) not the MJ (heat out) typically reported in New Zealand.

1. Hass und Sohn - <http://www.haassohn.com/en/products/wood-stoves.html>
2. Rikatronic Burners
3. Hark wood burners
4. Austroflamm
5. Ortner wood tiled stoves
6. Twin Fire

The Hass und Sohn burners are a low emission burner offering automatic air flow and control systems to minimise the potential for maloperation. The website indicated 32 models that met their “clean air” promotion emission limit of 40 mg/MJ⁶ with greater than 80% efficiency⁷. However, only ten of these also had the “patented automatic air control technology” that would assist in reducing emissions under real life operation.

The Rikatronic technology was introduced by Rika of Austria in 2007 and integrates temperature sensors and electronics to control the air supply and to advise when another log should be put on the fire through a light visible on the front of the fireplace. This seems to be the most advanced technology for a batch fed/ manual wood log burner in terms of automating the reloading and ensuring optimum firebox temperatures for reducing emissions. Rika wood burners with the Rikatronic technology include the Eco, Cult, Fox II and Imposa. An early model Rikatronic burner was included in the testing done by Keltz et al., (2010) which indicated real life emissions around 47 mg/MJ.

The Hark wood burners contain an integrated ceramic filter for reducing particle emissions.

The Austroflamm technology integrates a Heat Memory System which comprises a very heavy material, which can absorb warmth especially well and releases it for a long period of time. The material is patented as is the positioning of it around the stove to maximise capture and storage.

The Ortner wood tiled stoves utilise fire bricks and other such materials to capture and store heat and are common in Austria. Keltz et al., (2010) included real life testing of a wood tile stove in Austria which gave particulate emissions of around 30 mg/MJ.

The Twinfire®-System is based on the principle of gasification with the use of the furnace and has two combustion levels. The operating manual states that the fire burns at temperatures in excess of 1000 degrees C and is extremely efficient. There does, however, seem to be the potential for increased emissions through incorrect operation and at start up.

⁶ Note this is not comparable to outputs from New Zealand test methods.

⁷ There are differences in calculating efficiencies between New Zealand and European Countries which means results in the New Zealand efficiencies being reported approximately 10% lower than in Europe.

3.4.2 Secondary technology – particle precipitation devices

The development of particle precipitation devices has accelerated in recent years with the introduction of stricter emission limits for wood burners, particularly in Germany, Austria and Switzerland. An evaluation of the present state of particle precipitation devices for residential biomass combustion with a nominal capacity up to 50 kW was carried out by (Oberberger, & Mandl,., (2011)). The main groups of particle precipitation devices evaluated were electrostatic precipitators (ESP), flue gas condensers, ceramic filters and catalytic converters.

Of these, the ESPs were considered the most promising technology although the individual evaluations identified issues with all of the devices. These tended to have precipitation efficiencies of 50-85% although this depends on fuel and the combustion technology, with greater efficiencies occurring with older (more polluting) technologies. Most of the ESPs were fitted with an automatic cleaning system although some required manual cleaning. Maintenance is required and the typically the filter ash must be removed manually. The costs of the ESPs are around 1,000-3000 Euros and there are additional costs for installation. There is also an on-going cost associated with maintenance of the system.

Catalytic converters tested in the study appeared reasonable. For example, the MEKAT (Germany) was a catalytic converter that could be used on wood log stoves and had a rating of above 35% efficiency for removal of TSP. The main limitation of this technology was that it needs cleaning after eight hours of operation and that there was no reduction in emissions during start up because of low flue gas temperatures.

The Dr-Pley catalytic converters are an advanced technology for reducing particulate emissions. The following information is provided by the manufacturers (“Dr Pley,” 2012).

“The ChimCat RETRO products are designed to be retrofitted on existing or new fireplaces. The emission reduction for CO is up to 88% and for dust up to 70% under testing conditions. Under real operation we achieve up to 65% for CO and around 50% for dust. The ChimCat CAN products are parts for new fireplaces. They are integrated by stove manufacturers in their shop and sold with the new appliances. A lot of European manufacturers already use our technology which is the most efficient one on the market at the moment. These new fireplaces sometimes reach CO emissions of less than 100mg/m³ and dust emissions of less than 10mg/m³. The reduction rate can be up to 96% if the catalysts are integrated.

4 Historical research questions

A number of questions have been raised throughout the research into real life emissions from solid fuel burners in New Zealand. This section considers whether each of these questions is still relevant a) in a New Zealand context and b) in an international context. New research questions are also formulated based on this evaluation and the international review.

Based on scientific understanding following the 2007 testing of low emission burners in Nelson, Rotorua and Taumarunui, Smith et al., (2009) raised a number of research questions. These are outlined in bullet points below with an evaluation of the current relevance in italics.

- How do the real-life emissions measurements compare to the AS/NZS4013 results for comparable units?

The sample size (36 households for low emission burners) is too small to show a correlation between real life emissions and laboratory test data (AS/NZS4013) because of the large variability in emissions occurring as a result of household operation and fuel quality. Although relevant in a New Zealand context the sample size would need to include a representative range of burner operation for each AS/NZS4013 result. Internationally this is still relevant as many jurisdictions set a laboratory based emissions criteria for batch fed cordwood stoves. A more practical question to answer would be do low emission wood burners perform better in real life on average than older wood burners.

- How do the real-life emission factors measured here compare to the emission factors currently used in inventories? Do these results have any potentially significant impacts for emission inventories or emission reduction strategies?

The average emission factor for low emission burners (4.3 g/kg) is higher than those used historically for low emission burners in emission inventories and emission reduction strategies. This has minimal impact on historical emission inventories but would have increasing impact as low emission burners become more prevalent if the emission factor remained unadjusted.

The impact on emission reduction strategies is more significant as most measures adopted or considered rely on the replacement of older wood burners with low emission burners. The differential between emissions from these is the main variable influencing the anticipated reductions.

The average real life emissions from older wood burners (11 g/kg) compares well with emission factors used in inventories and emission reduction strategies.

These emission factors are relevant in a New Zealand context but unlikely to be representative of appliance types used overseas. The question is still relevant in New Zealand because of on-going uncertainty about the accuracy of the emission factor for low emission burners.

- What factors are associated with variation of emissions and how may this work be used to assist other investigations to evaluate the impact of different variables on emissions? For example, Auckland Regional Council is currently undertaking laboratory trials of woodburner emissions to develop a domestic fire emission model.

It is unclear whether a domestic fire emissions model is an appropriate objective. The interaction between different variables is complex and likely burner specific. Consequently the amount of testing required to come up with emission factors for all likely combinations of burners and operation would be significant. In addition surveying of the population to ascertain their operational characteristics to the degree of complexity required could be challenging.

- An investigation of results from different urban areas could be useful to identify possible reasons for any variability that may be observed

This question is still relevant in a New Zealand context and results of investigations into regional variations may be of value in an international context to help provide insight into variability in emissions.

- Investigate the effect of wood moisture on emissions and compare this to results from other New Zealand studies

The relationship between wood moisture content and particulate emissions has been evaluated for some of the testing programmes but no overall evaluation of the impact of wood moisture has been carried out. A parabolic relationship described by the polynomial $y=0.095x^2-5.1x+75.5$ ($r^2 = 0.63$) where x is wood moisture content (%) and y is particulate emissions (g/kg) is detailed in Wilton et al., (2006). In Wilton & Bluett, (2012b) 43% of the variability in particulate emissions was found to be associated with wood moisture content. Wood moisture content is known to impact on particulate emissions. However, data from household one for Taumarunui (Table 2.2) shows that wood with a high moisture content (51%) can be burnt cleanly (average particulate of 1.3 g/kg wet weight). No evaluation has been done on impact of moisture content across the

whole data set. Questions relating to the impact of wet wood would remain relevant in the context of designing a domestic fire emissions model should this be pursued. In this context the question would relate to particulate emissions from the burning of wet wood under different operating conditions. This would also be a relevant research topic internationally.

- Is the mean value of real life home heating emission factors the most useful value to use for emission inventories? Or are there alternative measures that should be considered?

Kelly et al., (2007a) concludes that the arithmetic mean is the most appropriate measure for emission inventory purposes. However, other measures that take into account the distribution of data may be appropriate for emission reduction strategy modelling if options targeting poor burner operation, for example, were to be considered. A larger data set of real life tests would be beneficial both in estimating an emission factor for “poor operation” and in determining the proportion of households likely to fall into this category. The international relevance of this question is unknown.

- Are there alternative and more reliable methods of monitoring real life emissions from woodburners than the equipment used for this programme?

This question was raised following a study utilising the ARS method described in section 2.2.2 of this report. The subsequent study of real life emission in New Zealand utilised a different method (the big blue box method described in Appendix A). Whether the latter method represents improved reliability, however, is questionable. Both types of approaches have been used internationally. Gravimetric methods are most common internationally, although a light scattering method was used in addition to gravimetric sampling to give real time emissions in Angelino et al., (2008). An evaluation of the advantages and disadvantages of each method and investigations into alternative options would be of value.

- Do woodburners with AS/NZS4013 emissions of less than 1.0 g/kg produce lower emissions in real-life than burners with standard emissions between 1.0 to 1.5 g/kg?

This research question has not been answered by studies carried out in New Zealand to date. It is still a valid question nationally particularly for Councils that have opted for lower emission standards than the 1.5 g/kg required under National Environmental Standards. The concept of whether small scale reductions in test based emissions criterion would result in reductions is likely to be of interest internationally.

A number of questions were identified following an evaluation of factors influencing variability in emissions for the same study. These were reported in Wilton & Bluett, (2012b) as follows:

- The limited data set collected in this study will facilitate the refinement of emissions factors used in emission inventories and help explain the reasons for high house-to-house and night-to-night variability in emissions. Both these issues are vital pieces of information that will allow Regional Councils to understand and manage particulate emissions from woodburners. Given the importance of these issues and the limited data base available to date, it is recommended that further work be done on NES authorised wood burners and factors influencing variability.

Further work on low emission burners remains a key area of further research.

- In this study, malfunction of the sampling equipment resulted in poorer quality data for around a third of the samples. Investigations into methods for minimising sampling equipment malfunctions are recommended before further studies are undertaken.

The study this recommendation came from used the ARS method and subsequent study was carried out using the "Big Blue Box". Both methods appear to have challenges.

- Investigations into real life emissions and factors influencing variability for other burner types are also required. In particular little is known about emission from coal burners in New Zealand and factors influencing variability in these.

This remains a relevant research area that has not been investigated and is critical to air quality management in areas such as Invercargill, Gore and Reefton. It is of limited significance in Europe as the burning of coal in domestic batch fed burners is less common. It may be of relevance to some developing countries where domestic coal burning is common.

- Councils give consideration to measures to improve the quality of wood burnt, specifically the moisture content (e.g., good wood scheme for Nelson), and options for ensuring appropriately sized wood burners are installed and operated well.

This recommendation is about communication and providing information rather than conducting research. Many Councils are looking at measures to improve wood quality as a part of the development of air plan measures so the message has

reached some Councils. Further communication, perhaps via the National Air Quality Working Group may be appropriate.

(Wilton & Bluett, 2012b) make the following recommendations

- Further studies of daily average fuel consumption in Christchurch and other places be carried out.

Further research into fuel consumption rates nationally and factors influencing this would be of value. Generally the average daily fuel consumption from the real life testing studies has been consistent with amounts estimated in emission inventories (through surveying households). However research into reasons for differences in fuel consumption including lifestyle factors, ambient temperature, fuel type and quality and house size may improve understanding of these variables which could assist in estimating fuel quantities in areas where inventory surveys have not been carried out. Many of these variables will be specific to New Zealand and international extrapolation of results is likely to be limited.

- Data on indoor PM₁₀ concentrations be further analysed to better characterise the relationship between ambient PM₁₀ concentrations and indoor concentrations and to examine potential influences of non-solid fuel burning indoor sources.

The impact of wood burners and other indoor sources on indoor air quality is still relevant nationally and has international significance.

- Further emission testing be carried out to:
 - improve our understanding around an appropriate emission factor for NES compliant burners
 - determine potential inter Region variability in PM₁₀ emissions
 - further characterise the temporal profile of emissions from wood burners

Evaluation of the data set as a whole strongly supports further testing of low emission burners. The issue of inter Region variability might be more broadly categorised as investigations into causes of differences in the distribution of the data rather than only looking at location specific causes. Other factors that may be considered are whether particular appliance types might perform better than others in real life. The question of real life emissions from low emission burners would have some relevance internationally, but would be of most value to New Zealand and Australia.

5 Discussion

5.1 Impact of fuel type

Fuel type can influence particulate emissions by a factor of ten (Kistler et al., 2012) . Fuel types examined in overseas studies are typically beech wood, white oak and spruce and are not typical of fuels used in New Zealand where softwoods such as pine, macrocarpa, and douglas fir are more prevalent. New Zealand studies of the impact of wood type include Scott, 2005 and Xie et al., (2012). In Xie et al., (2012) emissions from pine were higher than from blue gum and macrocarpa, although the latter was not statistically different. In Scott, 2005 burning of macrocarpa and eucalypt were reported as giving higher particulate emissions than pine and douglas fir lower than pine but it is uncertain if differences were statistically significant. A study of the impact of fuel type on particulate emissions in Australia found emissions from pine higher than from red gum, blue gum and jarrah (Gras & Australia. Environment Australia, 2002).

5.2 Units for emission limits

Internationally the predominant unit for expressing emissions is mg/MJ (heat in). In New Zealand the common method of expressing results is g/kg. It is recommended that future studies in New Zealand express emissions in g/kg and mg/MJ (heat in) to enable comparison to overseas data. The calorific value of New Zealand pine (pinus radiata) is 20.2 MJ/kg dry weight (EECA, 2012). The wet weight calorific values are 15.47 MJ/kg (16% moisture content), 14.61 MJ/kg (20% moisture content) and 13.55 MJ/kg (25% moisture content).

The comparable emission factor for 1.5 g/kg in mg/MJ based on pine with a moisture content of 20% is 102 mg/MJ. If the unit is expressed on a dry weight basis the equivalent for the 1.5 g/kg limit is 74 mg/MJ.

5.3 Emission factors for wood burners

Air quality management in New Zealand is largely based on the premise that there is a relationship between emissions under test conditions and those that occur when wood burners are operated in real life. This premise is not unique to New Zealand as most countries that wish to control emissions from domestic heaters have set emission limits for burners based on a laboratory testing situation.

The accuracy or otherwise of this premise cannot be determined by testing of the relationship between real life and laboratory tests within a limited range of burner types (e.g., low emission) because test data shows there is wide range in particulate emissions from low emission burners and that variability in operator behaviour and fuel quality has a profound impact on emissions. For example, within the low emission

burner category (<1.5 g/kg tested to NZS 4013), a well operated higher emission burner (e.g., 1.3 g/kg) can perform better than a poorly operated lower emission burner (0.9 g/kg burner). The test in terms of the effectiveness of using emission limits as an air quality management tool or a wood burner swap out programme becomes “on average, do burners that meet a particular emission limit perform better than those that don’t”.

To date there is real life test data from 36 households with NES compliant low emission wood burners. The average emission factor based on these households is 4.3 g/kg (wet weight). This compares with an average emission of 11 g/kg from the real life testing of 12 older wood burners (Wilton & Smith, 2006).

The distribution in emissions across the different studies looking at low emission burners raises further questions about potential reasons for variability. For example all twelve households tested in Rotorua and Nelson had emissions of 4.5 g/kg or less and all but one household had emissions less than 2.8 g/kg. In Christchurch only one of nine households had an average emission of less than 2.8 g/kg. Given the large variability within and between studies it would seem unlikely that the current suite of households and studies provide representative particulate emission factors from low emission wood burners in New Zealand. It is uncertain whether the differences are exacerbated by location specific factors. It would be interesting to know whether some specific models resulted in lower real life emissions. However, there are likely to be challenges in obtaining a representative sample size for each appliance being considered given it is unlikely that the current testing of 36 households adequately represents the distribution of average operation.

Further work testing real life emissions from low emission burners in the field is recommended. An approach similar to the Smith et al., (2009) study which involves testing in more than one location would be of value. It is recommended that Christchurch be included as one of these locations and an alternative location, such as Nelson where consistently lower emissions have been measured.

The emission factor for the older wood burners appears to be accepted despite a relatively low number of households being included in the programme. This may be because results appear consistent with overseas studies of similar aged burners, e.g., (Li, 2012) and existing emission factors. Further work on emissions from these older burners would be of value.

5.4 Research design

One of the key questions arising from this work is the research design and the sample sizes necessary to be representative of average emissions. International and local

research into real life emissions from wood burners has typically been carried out using one of two approaches:

- Simulating real life in the laboratory and quantifying the impact of variables on emissions (e.g., Xie, Mahon, & Peterson, (2010), Schmidl et al., (2008))
- In field testing of real life emissions from households (e.g., (Bluett & Meyer, 2011b; Smith et al., 2009; Wilton et al., 2006))

A key issue for both approaches appear to be the number of samples required to give something representative in terms of emission factors. This has not been a key consideration of existing studies, perhaps because the resources required are so significant that a degree of pragmatism is required.

The approach of quantifying the impact of variables on emissions could be used to establish emission factors for wood burners based on a distribution of these behaviours amongst households in real life, presumably obtained through a survey, as originally proposed in Scott, (2005). This approach would require more in-laboratory type testing to characterise the impacts of different variables and would require the testing of all the combinations of different variables. For example a relatively simple regime might include wood types (5 species), wood moisture (3 options), operational settings (3), reload amount (2 different kg options), reload frequency (3 frequencies), fuel size (2 average sizes) and 10 models of low emission burners. This would require 5400 test runs to include all combinations of variables assuming each combination is only tested once (normal test procedure is to carry out three test runs and take an average). A further limitation of this approach, as highlighted in Scott (2005) is the difficulty in actually characterising household burner operation. For example, a survey might indicate that a householder operates their fire on low burn for 70% of the time and 30% of the time on high burn but the timing of the transitions between these settings relative to the loading of wood will impact on the emissions. Adequately quantifying behaviour in a way that adequately reflects all the potential variability in emissions is problematic.

5.5 Research priorities

The following research questions are proposed based on an evaluation of historical questions and inclusion of questions raised based on this evaluation.

- 4) Further real life testing of low emissions burners would assist in the following areas:
 - a. *Evaluation of the extent to which more data might change the average emission factor for NES compliant burners.*
 - b. *Further understanding of the distribution of data including deriving an emission factor for poor operation and the proportion of households likely to operate burners poorly.*

c. Evaluating the causes of differences in the distribution of the data (for example regional differences or whether particular appliance types might perform better than others).

- 5) A comparison of the advantages and disadvantages of the two methods used in New Zealand, and any other possible options, should be carried out before any further studies are undertaken.
- 6) Further research into fuel consumption rates nationally and factors influencing this. In particular, do older burners use more or less fuel than low emission burners?
- 7) To what extent do emissions from low emission burners used in New Zealand increase with burner age and use?
- 8) What is the impact of non-compliance of burner models with authorised design on real life emissions from burners? What is being done about the issue of non-compliance by regulators?
- 9) Is the emission factor for older wood burners from Wilton et al., (2006) representative?
- 10) Investigations into emissions from coal burners in New Zealand and factors influencing variability in these.
- 11) Further investigations into indoor PM₁₀ concentrations to better characterise the relationship between ambient PM₁₀ concentrations and indoor concentrations and to examine potential influences of non-solid fuel burning indoor sources

5.6 Collaboration with overseas organisations

Many countries have specific expertise in research on emissions from burners that would be of value to New Zealand.

Collaboration and greater interaction with overseas organisations may help with improving consistency in methods and reporting parameters such as protocols for defining the cold start period and a definition of when the fire is out. For example, conclusion of the burn cycle could be based on:

- The temperature in the stack. For example in Li, (2012) the completed combustion cycle was defined by the temperature in the chimney being less than 93.3 °C when measured at 30.5 cm above the fire box.
- The weight of the fuel remaining in the fire or the change in the fuel weight with time. For example, (Schon & Hartmann, 2012) concluded measurement when the weight of fuel remaining reached 4% of the original mass of the fuel was reached.
- The carbon dioxide or oxygen gas concentrations in the chimney.

Testing of real life emissions from wood burners appears to be a current research priority in Austria. Key researchers include Christoph Schmidl (Bioenergy2020) and Thomas Brunner (Bios-bioenergy).

6 Summary

The objective of this report was to identify and prioritise future research relating to wood burner emissions in New Zealand based on a summary of research carried out in New Zealand and internationally. Issues considered included emission limits, test methods, real life tests, impacts of fuel and innovative technology.

Research into real life emissions from both older and low emission wood burners has been carried out in New Zealand. The average emission factor for low emission burners in New Zealand based on in home measurements where the fire has been operated by the homeowner in 36 households is 5 g/kg (wet weight). Similar testing of 12 households using older wood burners gave an average emission factor of 11 g/kg (wet weight).

Internationally the approach to evaluating real life emissions to date has focused on laboratory testing using simulations of real life operation and tests to determine real life emissions, the impact of start-up (cold start) and the influence of poor operation and wood quality and type. Results from overseas testing indicate real life emissions less than 100 mg/MJ are possible (equivalent 1.5 g/kg for pine). However, results from New Zealand studies suggest simulations of real life emissions may significantly under predict emissions relative to operation by householder.

The focus of future testing should be on in home testing rather than the development of an emissions model based on testing of variables and combinations of variables and making estimates of population behaviour with respect to those variables. This is also the conclusion reached by Scott (2005) following a detailed in laboratory and in home study.

The top three research priorities for developing this work were identified as:

- 12) Further real life testing of low emissions burners would assist in the following areas:
 - a. *Evaluation of the extent to which more data might change the average emission factor for NES compliant burners.*
 - b. *Further understanding of the distribution of data including deriving an emission factor for poor operation and the proportion of households likely to operate burners poorly.*
 - c. *Evaluating the causes of differences in the distribution of the data (for example regional differences or whether particular appliance types might perform better than others).*

- 13) A comparison of the advantages and disadvantages of the two methods used in New Zealand, and any other possible options, should be carried out before any further studies are undertaken.
- 14) Further research into fuel consumption rates nationally and factors influencing this. In particular, do older burners use more or less fuel than low emission burners?

Collaborating with internationals working in this area is also recommended to assist with the development of consistent methods and to promote achievement of mutual goals.

7 References

- Advanced Business Resources. (2006). Central Otago Home Heating and Air Pollution 2006 survey findings. Otago Regional Council Report.
- Angelino, E., Bertagna, S., Caserini, S., Giudici, A., Hugony, F., Marengo, S., ... Migliavacca, G. (2008). Experimental investigations of the influence of transitory phases on small-scale wood combustion emissions. In *AAAS08*. Naples, Italy. Retrieved from <http://www.aidic.it/aaas08/webpapers/54Angelino.pdf>
- Australian Department of Environment and Heritage. (2004a). National Woodheater Audit Programme Action Plan.
- Australian Department of Environment and Heritage. (2004b). National Woodheater Audit Programme Report.
- Barnett, S. (1985). Handbook for Measuring Woodstove Emissions and Efficiency Using the Condar (Oregon Method 41) Sampling System", . Condar Co.
- Bluett, J., & Meyer, M. (2011a). A method to measure of Real-world particulate emissions from domestic wood burners. Presented at the . 104th Air and Waste Management Association conference, Orlando Florida.
- Bluett, J., & Meyer, M. (2011b). Measurement of Real-world particulate emissions from domestic wood burners – Christchurch 2009. Presented at the 20th International Clean Air and Environment Conference, Auckland.
- Bluett, J., Wilton, E., Franklin, P., Dey, K., Aberkane, T., Peterson, J., & Sheldon, P. (2007). PM10 in New Zealands Urban Air: A comparison of monitoring methods. NIWA Client Report 2007-0.
- Department for Environment Food and Rural Affairs. (2012). UK Smoke Control Areas. Retrieved from <http://smokecontrol.defra.gov.uk/appliances.php?country=a>
- Dr Pley. (2012). Retrieved from <http://www.dr-pley.com/>

- EECA. (2012). Biomass calorific value calculator. Retrieved from <http://www.eecabusiness.govt.nz/wood-energy-resources/biomass-calorific>
- European Environment Agency. (2012). Air Pollution. *European Environment Agency*. Retrieved from <http://www.eea.europa.eu/themes/air/dcvvv>
- Gimson, N. (2012). Airshed Modelling of Exposure to Particulates in the Hawke's Bay Region. Golder Report Number 1178104049_001_R_Rev0.
- Gras, J. L., & Australia. Environment Australia. (2002). *Emissions from domestic solid fuel burning appliances*. Canberra: Environment Australia.
- Houck, J., Pitzman, L., & Tiegs, P. (2008). Emission Factors for New Certified Residential Wood Heaters. Presented at the 17th Annual International Emission Inventory Conference "Inventory Evolution - Portal to Improved Air Quality," Portland, Oregon - June 2 - 5, 2008. Retrieved from <http://www.epa.gov/ttnchie1/conference/ei17/session4/houck.pdf>
- Karvosenoja, N., Johansson, M., Kindbom, K., Lükewille, A., Jensen, D., Sternhufvud, C., & Illerup, J. (2004). FINE PARTICULATE MATTER EMISSIONS FROM RESIDENTIAL WOOD COMBUSTION AND REDUCTION POTENTIAL IN THE NORDIC COUNTRIES. Presented at the 13th World Clean Air and Environmental Protection Congress and Exhibition, London, UK. Retrieved from <http://www.umad.de/infos/cleanair13/>
- Kelly, C., Mues, S., & Webley, W. (2007a). Real life emissions testing of pellet burners in Tokoroa. Ministry for the Environment Warm Homes technical report no. ME813.
- Kelly, C., Mues, S., & Webley, W. (2007b). Real life emissions testing of wood burners in Tokoroa. Ministry for the Environment Warm Homes technical report no. ME814.
- Keltz, J., Brunner, Obernberger, P., Jalava, P., & Hirvonen. (2010). PM Emissions from Old and Modern Biomass Combustion Systems and their Health Effects. Presented at the 18th European Biomass Conference and Exhibition: from

- research to industry and markets, Lyon France: Produced and published by ETA-Florence Renewable Energies.
- Kistler, M., Schmidl, C., Padouvas, E., Giebl, H., Lohninger, J., Ellinger, R., ... Puxbaum, H. (2012). Odor, gaseous and PM10 emissions from small scale combustion of wood types indigenous to Central Europe. *Atmospheric Environment*, 51, 86–93. doi:10.1016/j.atmosenv.2012.01.044
- Kocbach Bølling, Anette, Pagels, J., Yttri, K., Barregard, L., Sallsten, G., Schwarze, P. E., & Boman, C. (2009). Health effects of residential wood smoke particles: the importance of combustion conditions and physicochemical particle properties. *Particle and Fibre Toxicology*, 6(1), 29. doi:10.1186/1743-8977-6-29
- KPMG. (2011). 2011 Wood Burner Audit Programme Summary of Findings. Unpublished report prepared for Ministry for Environment.
- Lamb, C. (1999). Christchurch Home Heating Survey: A survey of domestic home heating methods and fuels in the Christchurch metropolitan area. Environment Canterbury, U00/34.
- Lamb, C. (2003a). Household solid fuel heating 2002, Christchurch home heating diary panel. Environment Canterbury - unpublished report.
- Lamb, C. (2003b). Public Survey: Woodburner operation and wood type survey of Christchurch resident. Environment Canterbury Report U05-36.
- Li, V. (2012). Wood stove emissions.
- Meyer, M., Luhar, A., Gillet, R., & Keywood, M. (2008). Measurements of real world PM10 emission factors and emission profiles from wood-heaters by in situ source monitoring and atmospheric verification methods. Retrieved from <http://www.environment.gov.au/atmosphere/airquality/research/carp.html>
- Millichamp, P., & Wilton, E. (2002). Reducing emissions from domestic home heating. Ministry for Environment, Technical Report No. 26.

Ministry for Environment. (2007). *National Wood Burner Performance Review - Phase 1*.

Ministry for Environment. Retrieved from <http://www.mfe.govt.nz/publications/air/national-wood-burner-review-jun07/national-wood-burner-review-jun07.pdf>

Nielsen, O.-K., Mikkelsen, M., Hoffmann, L., Nielsen, M., Gyldenkærne, S., Fauser, P., ... Bruun, H., G. (2011). Annual Danish Informative Inventory Report to UNECE: Emission inventories from the base year of the protocols to year 2009. National Environmental Research Institute □ Aarhus University - Denmark. Retrieved from <http://www.dmu.dk/Pub/FR821.pdf>

Obernberger, I., & Mandl, C. (2011, December). Survey on the present state of particle precipitation devices for residential biomass combustion with a nominal capacity up to 50 kW in IEA Bioenergy Task32 member countries. IEA Bioenergy. Retrieved from <http://www.ieabcc.nl/publications/Filter-study-IEA-final-version.pdf>

Ozil, F., Haas, F., & Trouve, G. (2007). SIZE DISTRIBUTIONS AND EMISSION FACTORS OF PM1 AND PM2.5 DURING WOOD COMBUSTION IN DOMESTIC FIREPLACES. In *DustConf*.

Schmidl, C., Luisser, M., Padouvas, E., Lasselsberger, L., Rzaca, M., Ramirez-Santa Cruz, C., ... Puxbaum, H. (2011). Particulate and gaseous emissions from manually and automatically fired small scale combustion systems. *Atmospheric Environment*, 45(39), 7443–7454. doi:10.1016/j.atmosenv.2011.05.006

Schmidl, C., Marr, I. L., Caseiro, A., Kotianová, P., Berner, A., Bauer, H., ... Puxbaum, H. (2008). Chemical characterisation of fine particle emissions from wood stove combustion of common woods growing in mid-European Alpine regions. *Atmospheric Environment*, 42(1), 126–141. doi:10.1016/j.atmosenv.2007.09.028

- Schon, C., & Hartmann, H. (2012). Logwood combustion in stoves - influence on emissions and efficiency. Presented at the 20th European Biomass Conference and Exhibition, Milano Italy.
- Scott, A. (2005). Real life emissions from residential wood burning appliances in New Zealand. Ministry for the Environment Sustainable Management Fund report, ID number 2205.
- Smith, J., Bluett, J., Wilton, E., & Mallet, T. (2009). In home testing of particulate emissions from NES compliant woodburners: Nelson, Rotorua and Taumaranui 2007. NIWA report number CHC2008-092.
- Wang, Y., Hopke, P. K., Rattigan, O. V., Xia, X., Chalupa, D. C., & Utell, M. J. (2011). Characterization of Residential Wood Combustion Particles Using the Two-Wavelength Aethalometer. *Environmental Science & Technology*, 45(17), 7387–7393. doi:10.1021/es2013984
- Wilton, E. (2012). International review of best technology for low emission wood burners. Environment Canterbury.
- Wilton, E., & Baynes, M. (2009). Product Profile - Residential Gas Heaters in New Zealand. Energy Efficiency and Conservation Authority Report.
- Wilton, E., & Bluett, J. (2012a). Factors influencing particulate emissions from NES compliant woodburners in Nelson, Rotorua and Taumarunui 2007. NIWA Client Report 2012- 013.
- Wilton, E., & Bluett, J. (2012b). Wood burner Testing Christchurch 2009: Diurnal variation in emissions, wood use, indoor temperature and factors influencing start-up. NIWA Client Report 2012- 020.
- Wilton, E., & Smith, J. (2006). Real Life Emissions Testing of Pre 1994 Woodburners in New Zealand. . Environment Waikato technical report no. TR06/05.

Wilton, E., Smith, J., Dey, K., & Webley, W. (2006). Real life testing of woodburner emissions. *Clean Air and Environmental Quality*, 40(4), 43–47.

Xie, S., Mahon, K., & Peterson, J. (2010). Effects of fuel and operation on particle emissions from wood burners. Auckland Regional Council Technical Report 2010/061.

Xie, S., Mahon, K., & Peterson, J. (2012). Effects of fuel and operation on particle emissions from wood burners, 46(1).

Appendix A: The big blue box test method

The following is a direct excerpt from (Meyer et al., 2008).

Sampler design

The system is required to measure the mass emission rates of particulate matter (PM). While this is a useful parameter, its applicability is limited unless related to wood consumption. In order to relate PM emission rates to wood consumption we also need to measure the emission rates of the main combustion products, carbon dioxide (CO₂) and carbon monoxide (CO) that together account for approximately 97% of the carbon content of the fuel that in turn constitutes approximately 50% of the fuel dry weight. To calculate the emission rate of a trace species i (E_i , g min⁻¹) of PM₁₀, CO₂ or CO, we must measure both its concentration (C_i , g m⁻³) in the woodheater exhaust and the flow rate of the exhaust (F , m³ min⁻¹), i.e.

$$E_i = C_i \times F . \quad (1)$$

CO₂ and CO concentrations are measured as mixing ratios (ppm) and PM₁₀ is measured as a mass concentration at standard temperature and pressure (STP). The gas density at the point of sampling is also required to convert volumetric concentrations to mass concentrations. To determine flue gas density we require the flue gas temperature and pressure.

Combustion gases usually have high concentrations of water vapour which condense when smoke samples are cooled to ambient temperatures. To prevent this, smoke samples must be diluted with dry air at the point of sampling to reduce the water vapour dewpoint to below air temperature. Usually, further dilution is required to bring the particulate and gas concentrations within sensor range. Particulate sampling has a further requirement: to minimise particle deposition onto the walls of the sample lines and the dilutors; these components must be electrically conductive with minimum bends (ideally none) and minimum length. The smoke sample must be analysed upstream of any pumps.

For field monitoring of domestic houses it is essential that the equipment:

- *Can be installed quickly, easily and safely;*
- *Is weather proof and free from safety hazards;*
- *Is unobtrusive and has, ideally, no impact on normal appliance operation or household activity. In particular:*

- *The equipment should be self contained and external to the house;*
- *It should require no on-site maintenance during the period of operation;*
- *It should be possible to monitor and control the equipment remotely to minimise the need for regular house visits to check system performance.*

In practical terms, this required a unit that could operate for at least a week without exhausting consumable components such as filters and scrubbers and operated on low voltage DC power. All operational parameters including air flow rates, temperatures and valve status were monitored continuously.

A system was designed to meet these specifications. It comprises three units: a smoke sampling unit, an analysis unit, and a power supply. The smoke sampler consists of a 1.2 m flue extension, 150 mm in diameter with a 100 mm orifice plate fitted 100 mm from one end. The orifice plate provides the means of measuring the flue gas volumetric flow rate. Flue temperature is measured using paired 1/16" stainless steel sheathed type K thermocouples. Midway along the flue extension a smoke sample is drawn via an isokinetic inlet by a venturi. Clean air at a dewpoint of approximately 4 °C powers the venturi jet and also dilutes the smoke sample to reduce it's dewpoint as discussed above. This unit is referred to as the primary diluter.

Two airstreams are drawn from the primary diluter to the analysis unit. The sample air stream for particle analysis is drawn through ¼" copper tubing and is further diluted, in a secondary diluter housed in the analysis unit. The secondary diluter, which is based on the design of Gras et al. (2002), consists of a sample-loop that is alternately filled and then flushed with clean air into a mixing volume. With an appropriate combination of the valve switching duty cycle, the dilution air flow rate, and the sample-loop volume, dilution ratios between 1:50 to 1:1000 can be achieved. The particle concentration is measured continuously using a DustTrak laser scattering particle analyser (TSI, USA) fitted with a PM10 size selective inlet. In practice, the cutoff size is unlikely to have any impact in this application since most combustion aerosol is below 2.5 µm in diameter and particles larger than 1 µm will be lost by impaction to the walls of the 5 m inlet sample tube. The average weekly PM concentration is determined gravimetrically by sampling onto 47 mm stretched Teflon filters.

A second sample airstream is filtered before passing to a series of gas sensors. CO₂ concentration is measured by NDIR (Gascard II, 10,000ppm range, Edinburgh Instruments, UK) and CO is measured with Polytron-2 electrochemical sensors (0-1000 ppm range, DrägerSensor CO – 68 09 605, Draeger, PA, USA). It was intended to measure NO_x, however the corresponding NO_x sensor proved to have a strong negative interference for CO (0.5ppm at 100 ppm CO) and proved unsuitable for combustion gas

analysis in this situation. Alternative sensors are being sourced, but were not available in time for this study.

All critical air flow rates, temperatures and humidities are measured. The particle, chemical, flow and temperature sensor signals are monitored using appropriate industrial data acquisition interface devices (model 4017, 4017+,4018, Advantech, OH,USA). The system is controlled and the data is logged by a laptop PC. Using a GSM modem supported by appropriate remote-access software, the units can be monitored and controlled remotely.

The analysis unit was located at ground level; external to the house but as close to the flue as was practicable. This unit housed all the air supplies, pumps, filters, zero scrubbers, analytical sensors, data acquisition system and controller, and telemetry. Power to the system is supplied by a high capacity battery charger, supplying a series of DC- to-DC converters which in turn provide regulated power to the system components. A 12V 80Ah low maintenance lead/acid battery connected in parallel to the power supply provides limited backup power in the event of a power failure.

The instrument system is shown schematically in Figure A-0-1.

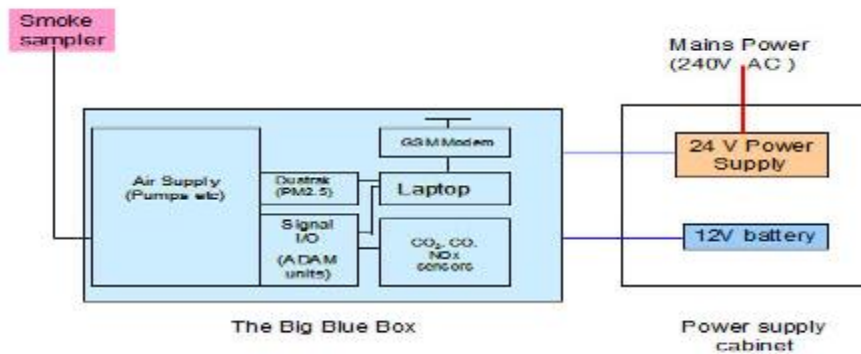

Figure A-0-1 Schematic diagram of the sampling system.

Flue extension and primary diluter

The flue extension comprising orifice plate and the primary diluter (isokinetic inlet, venturi and mixing chamber) are shown in Figure A-0-2. Following Gras et al. (2002) a dilution ratio of approximately 1:5 is sufficient to prevent condensation in diluted smoke samples at ambient temperatures above 5 °C.

The performance of the primary diluter is shown in Figure A-0-3. The vacuum generated by the venturi jet increases non-linearly with airflow. At high venturi jet velocities the backpressure from the mixing chamber limits the sample air flow rate. In the middle region the dilution ratio is relatively insensitive to venturi airflow. The three isokinetic inlets tested in this study sustained dilution ratios of 4.3, 5.03 and 5.7.



Figure A-0-2 The flue extension with primary diluter installed fitted in situ to a woodheater flue

Gras and Meyer (2003) reported that volumetric flow rate of the flue gas in woodheaters range up to $4 \text{ m}^3 \text{ min}^{-1}$. A 100 mm orifice plate was found to provide a measurable pressure differential within this range without noticeably restricting smoke flow. The orifice plate was calibrated against an annubar flow meter (Annubar, USA) to confirm that flows within the expected range were measurable with readily-sourced and mechanically-robust transducers (Figure A-0-4). A transducer with a full scale range of 0.25" water (62 Pa) was fitted to the each analytical unit.

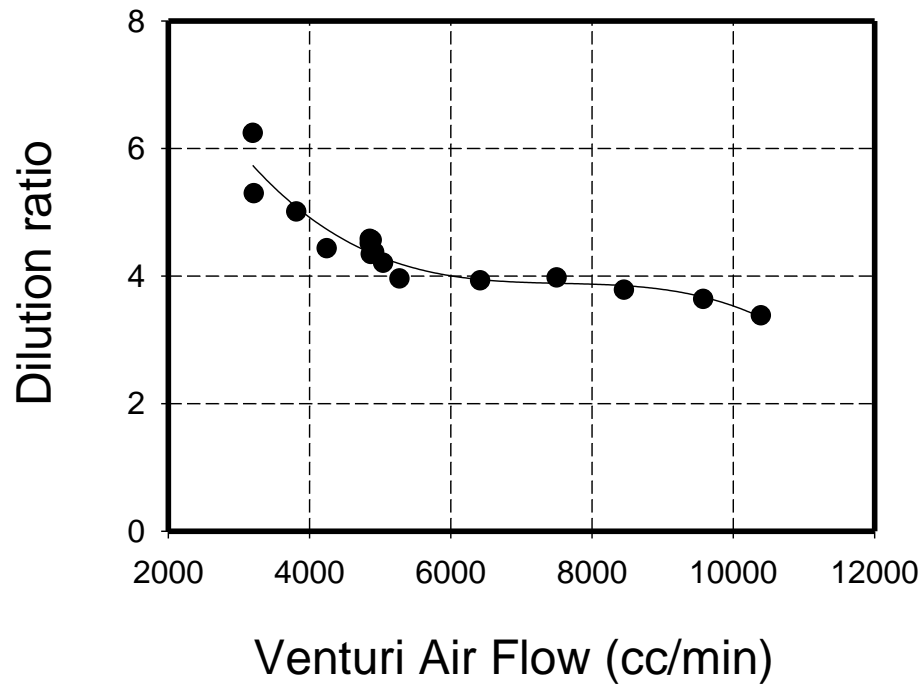

Figure A-0-3 The effect of venturi volumetric air flow rate on sample dilution ratio

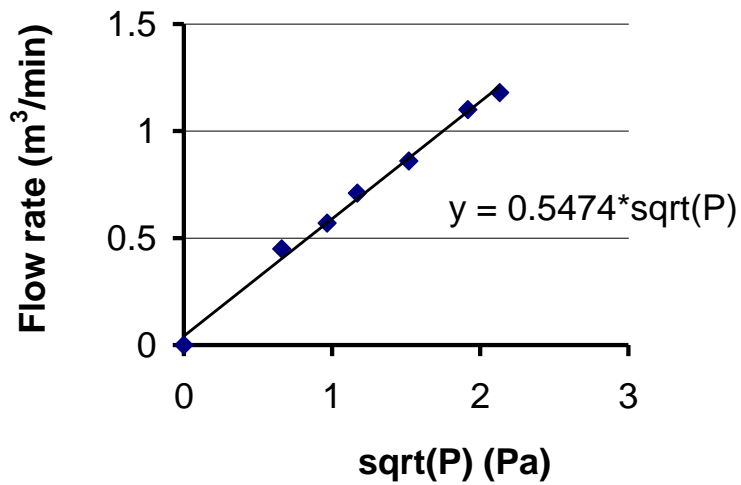

Figure A-0-4 Calibration of the flue extension against measured flow using an Annubar flow meter.

Analysis unit

The analysis unit was housed in a large weatherproof PVC container that could be placed in a convenient location at ground level. It was connected to the flue by umbilical consisting of Teflon and copper sample lines, thermocouple leads, primary diluter air supply and two pressure lines. Ideally, the umbilical should be as short as possible and, in practice, 15m length was found to be adequate in all locations tested.

The design of the monitoring system is shown schematically in Figure A-0-5. In brief, the analyzer provides three air streams:

- ambient air, filtered and dehumidified by a Peltier-cooled condenser, which supplies dilution air for the primary diluter;*
- a scrubbed and filtered zero air to periodically check the zero readings of the gas sensors; and*
- a scrubbed ambient air stream required for the second stage dilutions of the particle and gas samples.*

The second dilution of the particle sample stream takes place in the secondary diluter. This diluter comprises a sample loop of 5ml volume which is injected into a dilution air stream at a specified rate. This not only dilutes the sample but also changes the sample stream from negative to positive flow without passage through a pump. The injection rate and the dilution air flow determine the dilution ratio. This air supplies the DustTrak particle analyzer which continuously measures particle mass concentration, and three filter samplers connected in parallel. Two of the filters (47 mm stretched Teflon) collect particle samples for gravimetric mass determination which provides a direct calibration of the DustTrak. They are also analysed for ion composition and levoglucosan concentration. The third filter (47mm quartz-fibre) collects particle samples for organic and elemental carbon determination.

The gas sample stream is drawn through ¼" Teflon tubing and filtered before passing to the sensors. During field-testing it was found that the primary dilution was not always sufficient to bring the flue gas concentration within both CO and CO₂ sensor range, and therefore a secondary dilution step was also added to this stream.

The filters used to protect pumps and sensors from particle contamination comprise a pre-filter consisting of a gas drying tube packed with glass wool, and a 47mm diameter 1µm Teflon filter (Fluropore, Millipore). The pre-filter removes most of the particle mass extending the life of the Teflon filter to more than 10 days which is the maximum period for which a household was tested.

Flow rates of all supply-air and sample streams are monitored by mass flow meters; some of the flows are also controlled. Temperatures of all the airstreams, the analyzer housing and the gas detector enclosure are also recorded. Data is logged at 1 second

intervals then reduced to 1-minute averages. Both 1-second and 1-minute data are saved to file. The analysis unit is shown in Figure A0-6.

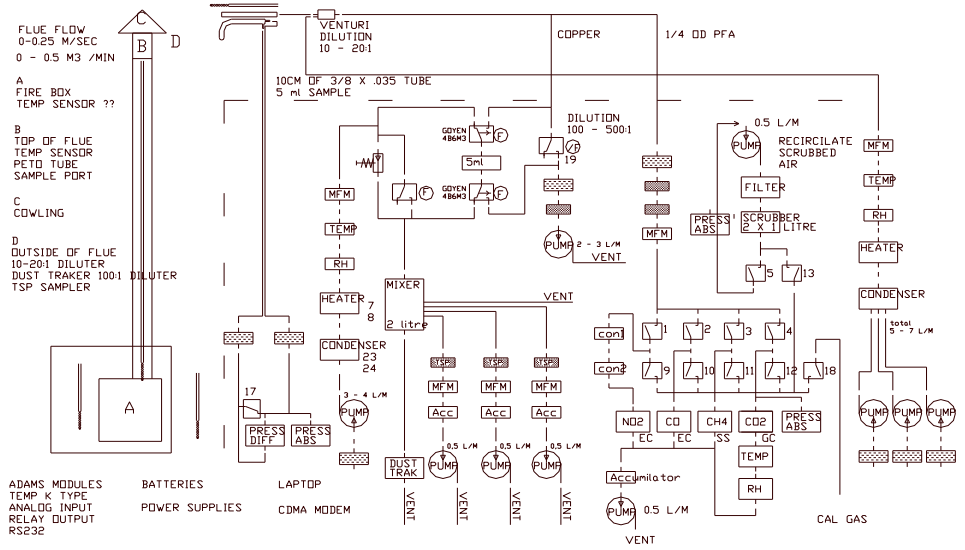

Figure A-0-5 Schematic layout of the analyzer unit



Figure A0-6 View of the analyzer unit containing air supplies, secondary diluter, particle and gas sensors and particle filter samplers.

Appendix B: Real life test data – summary statistics

Table B1 shows the summary statistics for particulate emissions from low emissions burners tested in home for real life emissions in New Zealand. Statistics are based on average household data to minimise any bias associated with different run numbers per household. Figure B1 shows the distribution of the test data across the four different studies. This shows the least spread occurs for the Tokoroa 2006 test programme. Figure B2 shows the distribution when data are considered based on location and indicates the largest range in concentrations for Christchurch and Taumarunui.

Table B1: Summary statistics of average household particulate emissions data for low emission burners (in home measurements conducted in New Zealand)

	Emissions g/kg (wet)
N of Cases	37
Minimum	0.4
Maximum	20.5
Range	20.1
Sum	186.4
Median	3.2
Arithmetic Mean	5.0
Standard Error of Arithmetic Mean	0.86
95.0% Lower Confidence Limit	3.28
95.0% Upper Confidence Limit	6.79
Trimmed Mean (10%, Two Sided)	3.81
No. of Observations Trimmed Out	8
Geometric Mean	3.24
Harmonic Mean	2.15
Standard Deviation	5.27
Variance	27.78
Coefficient of Variation	1.05
Skewness(G1)	1.87
Standard Error of Skewness	0.39
Kurtosis(G2)	2.8
Standard Error of Kurtosis	0.7

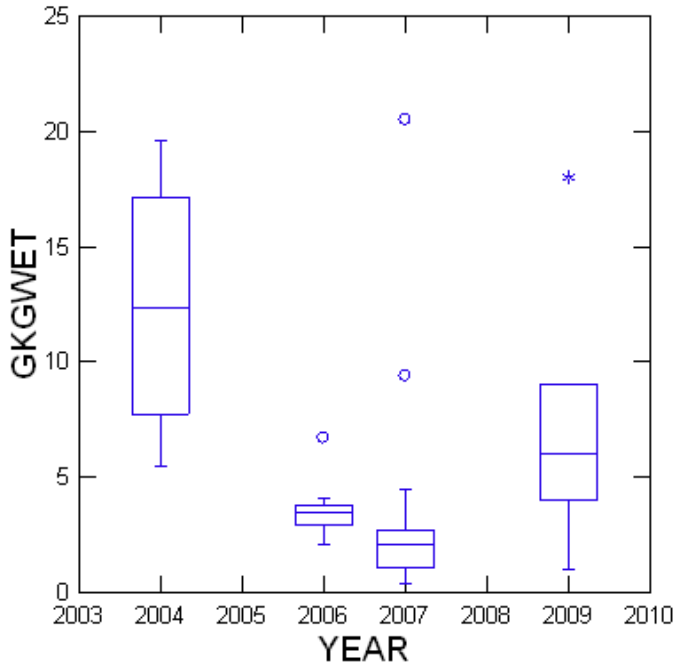

Figure B1: Distribution of particulate emissions data by testing programme. Boxes represent upper and lower quartiles; whiskers extend to 1.5 times the inter-quartile range (inter-quartile range, 75%-25%) and horizontal lines within the box are the median emissions for all runs at each household.

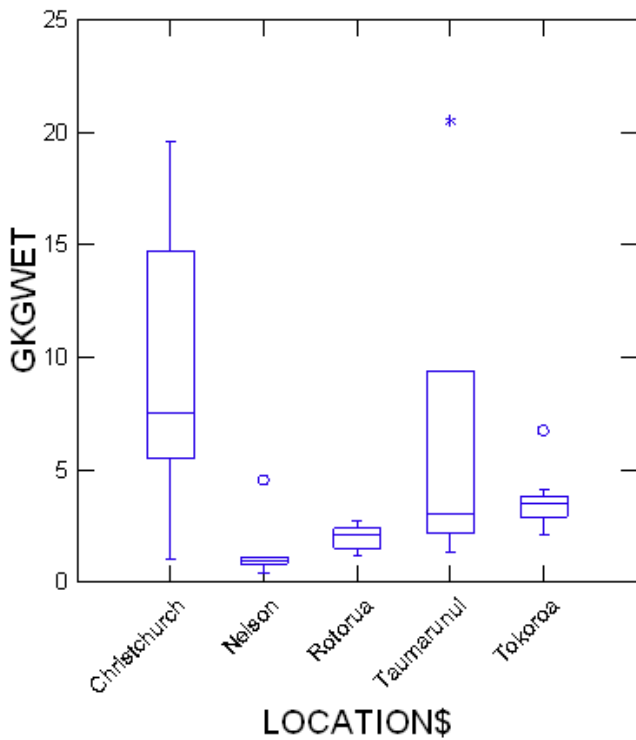

Figure B2: Distribution of particulate emissions data by location.

Appendix C: Comparison of laboratory simulations of real life and operation of householders in real life

Testing carried out for Scott (2005) highlights the difficulties in attempting to simulate real life operation either in a laboratory or in the field. In Table C1 the stage two testing has been done in the field by a laboratory technician attempting to simulate real life operation. The stage three results are the same burner in the same household but carried out by the homeowner using wood from their wood pile.

Table C1: Comparison of test parameters and emissions (g/kg, g/hr) from Scott (2005)

APPLIANCE A	STAGE 0	STAGE I	STAGE II	STAGE III
Number of test runs	9	9	6	7
Control settings (low, medium, high)	3L, 3M, 3H	3 L, 3 M, 3H	3L, 3M	18% L, 82% H
Flue height	4.6	4.6	4.2	4.2
kW rating	7.6	7.6	7.6	7.6
Firebox size (litres)	30.2	30.2	30.2	30.2
Hot water booster	N	N	N	N
Secondary air bar	N	N	N	N
Wood type	Pine	High resin pine	High resin pine	Pine - offcuts
Target wood loads (kg - wet weight)	2.9	1.5	1.5	1.3
Kindling number		6	6	
Kindling size (kg - wet weight)		0.25	0.25	
Medium log number	3	2	2	1-2
Medium/normal log size (kg - wet weight)		0.75	0.75	
Average moisture content (%)	16-20	15	14.9	16
Average fuel consumption (Total dry kg/hr)	2.3	2.1	1.3	0.9
Average run time	78	360	360	348
Average emissions g/kg	0.6	2.3	2.7	11.9
Average emissions g/hr	1.2	4.8	4.2	9.7
APPLIANCE B	STAGE 0	STAGE I	STAGE II	STAGE III
Number of test runs	9	9	6	7
Control settings (low, medium, high)	3L, 3M, 3H	3L, 3M, 3H	3L, 3M	4%L, 12%M, 84%H
Flue height	4.6	4.6	4.8	4.8
kW rating	9.1	9.1	9.1	9.1
Firebox size (litres)	49.2	49.2	49.2	49.2
Hot water booster	N	N	N	N
Secondary air bar	N	N	N	N
Wood type	Pine	High resin pine	High resin pine	Oregon - split logs
Target wood loads (kg - wet weight)	4.6	2.8	2.8	2.7
Kindling number		6	6	
Kindling size (kg - wet weight)		0.46	0.46	
Medium log number	4	2-3	2-3	
Medium/normal log size (kg - wet weight)		0.93-1.4	0.93-1.4	1-2
Average moisture content (%)	16-20	14	15.4	19
Average fuel consumption (Total dry kg/hr)	3.1	2.8	1.9	2.5
Average run time	96	360	360	427
Average emissions g/kg	1.1	2.7	2.3	18.2
Average emissions g/hr	3.2	7.7	5	41.7

APPLIANCE C	STAGE 0	STAGE I	STAGE II	STAGE III
Number of test runs	9	6	6	8
Comment	1.2 g/kg appliance	1.7 g/kg appliance	1.2 g/kg appliance	1.2 g/kg appliance
Control settings (low, medium, high)	3L, 3M, 3H	3L, 3M	3L, 3M	48%L, 13%M, 39%H
Flue height	4.6	4.6	7.5 m	7.5 m
kW rating	9	10.4	9	9
Firebox size (litres)	45.6	56.3	45.6	45.6
Hot water booster	Y	N	Y	Y
Secondary air bar	N	N	Y	Y
Wood type	Pine	Medium resin pine	Medium resin pine	Eucalypt - split logs
Target wood loads (kg - wet weight)	4.3	2.2	2.2	3.2
Kindling number		6	6	
Kindling size (kg - wet weight)		0.38	0.38	
Medium log number	4	2-3	2-3	1-2
Medium/normal log size (kg - wet weight)		0.75-1.3	0.75-1.3	
Average moisture content (%)	16-20	20.7	14.5	21
Average fuel consumption (Total dry kg/hr)	3.3	2.1	1.8	1.5
Average run time	101	360	360	647
Average emissions g/kg	1.2	3.6	4.7	6.9
Average emissions g/hr	3.2	7.5	9.6	10.3
APPLIANCE F	STAGE 0	STAGE I	STAGE II	STAGE III
Number of test runs	9			7
Control settings (low, medium, high)	3L, 3M, 3H			100%H
Flue height	4.6			4
kW rating	7.1			7.1
Firebox size (litres)	33.3			33.3
Hot water booster	N			N
Secondary air bar	N			N
Wood type	Pine			Pine - split logs
Target wood loads (kg - wet weight)	3.1			1.8
Kindling number				
Kindling size (kg - wet weight)				
Medium log number	5			1
Medium/normal log size (kg - wet weight)				
Average moisture content (%)	16-20			25
Average fuel consumption (Total dry kg/hr)	2.5			1.3
Average run time	78			223
Average emissions g/kg	0.9			26.1
Average emissions g/hr	1.9			36.7

APPLIANCE D	STAGE 0	STAGE I	STAGE II	STAGE III
Number of test runs	9	6	6	7
Comment				Same as Stage II but different house
Control settings (low, medium, high)	3L, 3M, 3H	3L, 3M	3L, 3M	3.8
Flue height	4.6	4.6	??	36%L, 30%M, 33%H
kW rating	6.8	6.8	6.8	6.8
Firebox size (litres)	40.1	40.1	40.1	40.1
Hot water booster	Y	N	Y	Y
Secondary air bar	N	N	N	N
Wood type	Pine	High resin pine	Medium resin pine	Pine and native timbers - split logs
Target wood loads (kg - wet weight)	3.8	1.7	1.7	2.3
Kindling number		6	6	
Kindling size (kg - wet weight)		0.29	0.29	
Medium log number	4	2	2	1-2
Medium/normal log size (kg - wet weight)		0.87	0.87	
Average moisture content (%)	16-20	14	13.6	21
Average fuel consumption (Total dry kg/hr)	2.2	2.2	1.6	1.4
Average run time	113	360	360	411
Average emissions g/kg	3.1	4.7	1.5	14.3
Average emissions g/hr	6	9.8	2.8	20
APPLIANCE E	STAGE 0	STAGE I	STAGE II	STAGE III
Number of test runs	9	6	6	7
Comment	1.8 g/kg appliance	Uncertain - either 1.8 g/kg or 1.3 g/kg appliance	Different to Stage I model - Uncertain - either 1.8 g/kg or 1.3 g/kg appliance	Same Stage II appliance
Control settings (low, medium, high)	3L, 3M, 3H	3L, 3M	3L, 3M	100%H
Flue height	4.6	4.6	??	3.5
kW rating	7.6	uncertain	uncertain	uncertain
Firebox size (litres)	uncertain	33.3	uncertain	uncertain
Hot water booster	N	N	N	N
Secondary air bar	N	N	N	N
Wood type	Pine	Medium resin pine	Medium resin pine	Pine and silver birch - split logs
Target wood loads (kg - wet weight)	3.9	1.9	1.9	1.5
Kindling number		6	6	
Kindling size (kg - wet weight)		0.32	0.32	
Medium log number	4	2	2	1-2
Medium/normal log		0.95	0.95	

size (kg - wet weight)				
Average moisture content (%)	17	20	19.2	16
Average fuel consumption (Total dry kg/hr)	2	2.2	1.4	1.2
Average run time	103	360	360	360
Average emissions g/kg	1.8	3	3.8	6.6
Average emissions g/hr	3.3	6.4	6.1	8